

Automatisieren
Dosieren
Messen
Montieren

EXACTLY YOUR **SOLUTION!**

PRODUCTS 2024

CONTENT

DOSING TECHNOLOGY

REMOVING / CONVEYING 4

HIGH PRESSURE BARREL PUMPS

Overview High pressure barrel pumps	6
High pressure barrel pump FP001	7
High pressure barrel pump FP015	8
High pressure barrel pump FP045	9
High pressure barrel pump FP045-T	10
High pressure barrel pump FP050	11
High pressure barrel pump FP050-T	12
High pressure barrel pump FP200	13
High pressure barrel pump FP200-T	14
High pressure barrel pump FP200-S	15

HIGH PRESSURE BARREL PUMPS ACCESSORIES

Reporting units	16
Pressure reducing and shut-off units	18
High pressure filters and mixing pipes	22
Follower plates and sealing rubber sets	24
Material pressure relief	25
General accessories	26

MATERIAL PRESSURE TANKS 30

Material pressure tanks accessories	32
-------------------------------------	----

DOSING / APPLYING 34

VOLUMETRIC DOSING

Dosing valve DV05	36
Dosing valve DV25	38
Proportional dosing valve PDV03	40
Proportional dosing valve PDV04	42
Dosing valve station	45
Mini dosing valve	46
Chamber dosing valve	48

TIME CONTROLLED DOSING

Grease shot valves	
Grease shot valve FSV02 single	50
Grease shot valve FSV02 accessories	51
Pressure booster	52

Spraying valves

Spraying valve SVEP	53
Spraying valve SVSV	54
Spraying valve SVKA	55

Extrusion valves

Extrusion valve EV40	56
Extrusion valve EV50	57
Extrusion / spraying valves accessories	58
Nozzle extensions	61

Outlet valves

Outlet valve AV25	62
Outlet valve	64

Rotary greasing units

Rotary greasing unit RBE02	65
Rotary greasing unit RBE03	66
Rotary greasing unit RBE04	67
Rotary greasing unit RBE accessories	68

DEVICES 69

CONTROLLING / MEASURING 70

DOSING CONTROLLER

Dosing controller DS03	72
------------------------	----

SENSORS

Flow meter SMG06	74
Flow transmitter SFG 01 and adapter cable	77
Volume sensor VCA0,04	78
Volume sensor VC0,025	79
Volume sensor VSE01	80
Ultrasonic flow sensor UDS	81

SPECIAL MACHINERY

ROBOTICS 84

DISPENSING 85

MEASURING / TESTING 86

AUTOMATING / ASSEMBLING 87

CUSTOM SOLUTIONS 88

STANDARD CELLS 89

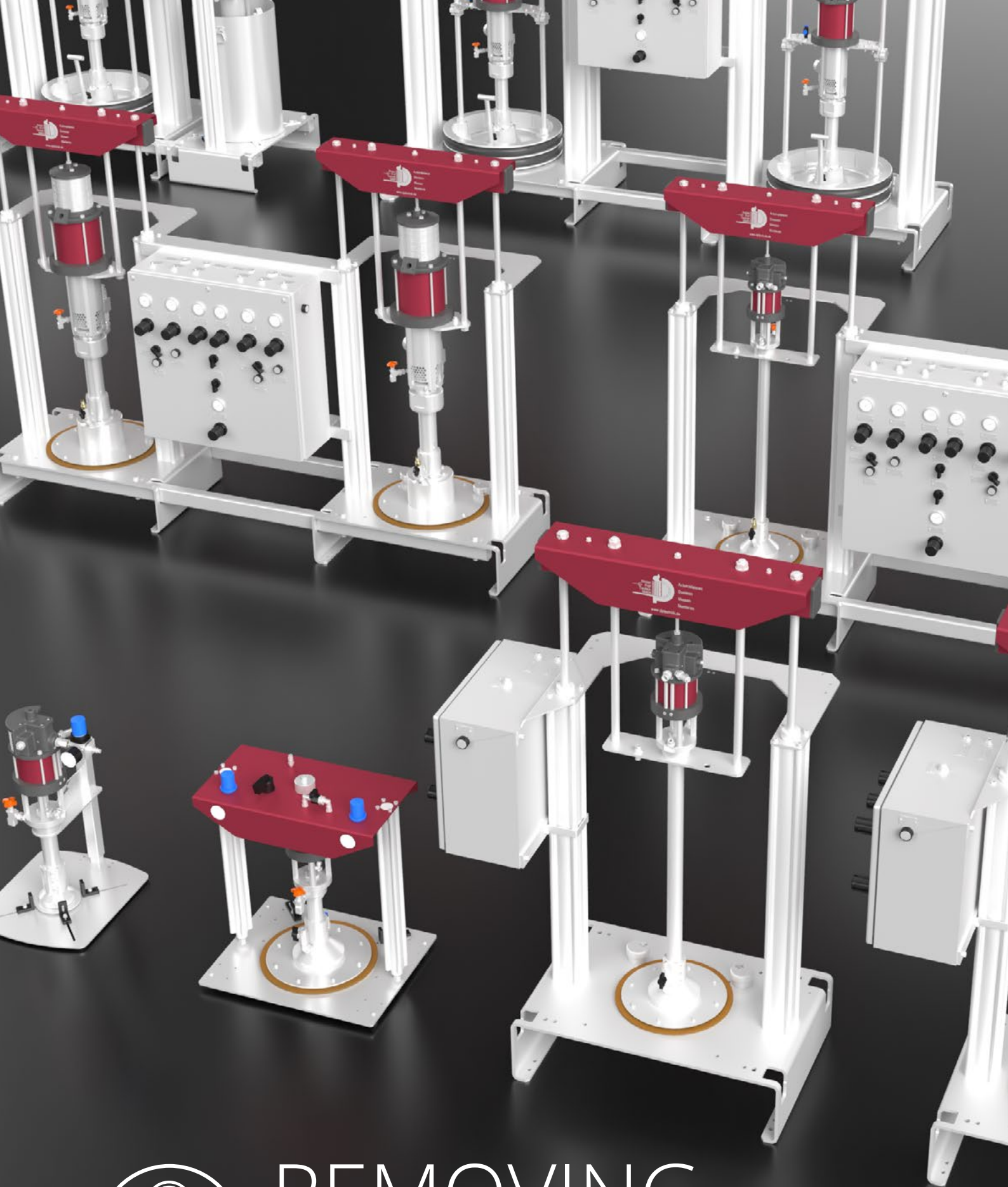

REMOVING
CONVEYING



OVERVIEW

Barrel pumps	6
Accessories material supply	16
Material pressure tanks	30

The pneumatically controlled D+P high pressure barrel pumps are characterized by high product quality, reliability and a long service life. The pumps developed in-house are subject to extremely strict quality control. Thanks to our in-house production, we can ensure optimum and technically perfect adaptation to customer requirements at all times.

Our high pressure barrel pumps are ideally suited as material feeders for dosing systems or for transfer and filling systems. They are suitable for all viscous media, e.g. greases, silicones, pastes and adhesives. They are available as standard for different container sizes from 1 to 200 liters.

On request, we can supply state-of-the-art accessories such as pressure reducing valves, outlet and dosing valves, high-pressure hoses, pressure switches, screw connections etc. for the high-pressure barrel pumps, which together with the grease dispensing point form a fully functional complete system.

Our range of services includes the installation, commissioning and integration of the high pressure barrel pumps into other systems as well as comprehensive customer service.

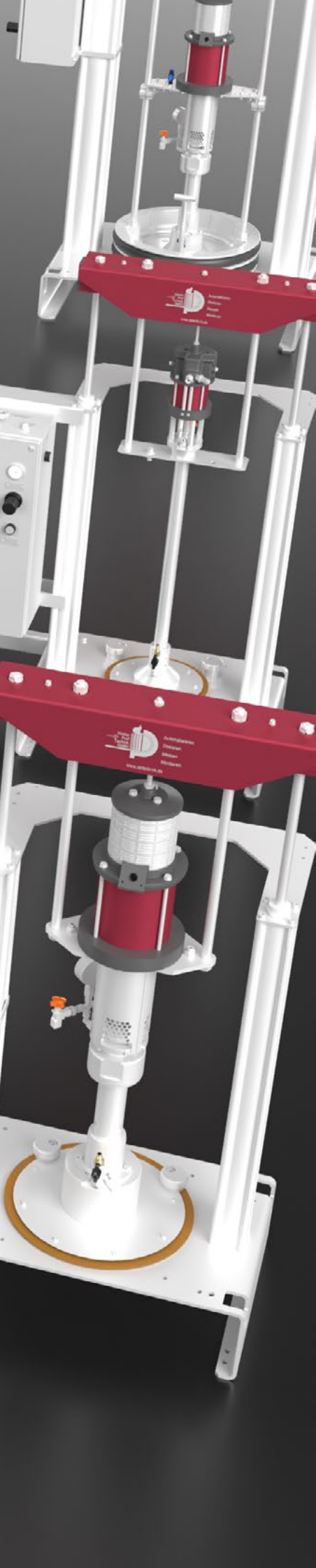



OVERVIEW HIGH PRESSURE BARREL PUMPS



	FP001	FP015	FP045	FP050	FP200
Pumping medium	lubricants up to NLGI class 3	lubricants up to NLGI class 3	lubricants up to NLGI class 3	highly viscous and solvent-free media	highly viscous and solvent-free media
Displacement/ double stroke	19 cm ³	19 cm ³	19 cm ³	79 cm ³	79 cm ³
Conveying capacity	1140 cm ³ /min	1140 cm ³ /min	1140 cm ³ /min	4740 cm ³ /min at 60 double strokes/min	4740 cm ³ /min at 60 double strokes/min
Transmisson	25:1	25:1	25:1	24:1 (FP050-24); 45:1 (FP050-45)	24:1 (FP200-24); 45:1 (FP200-45)
Diameter follower plate	customized	customized	customized	customized	530 mm
Max. container dimensions	1 kg can; height 200 mm	Ø 335 mm; height 360 mm	Ø 420 mm; height 670 mm	Ø 420 mm; height 670 mm	200 l standard barrel
	more	more	more	more	more



	FP045-T	FP050-T	FP200-T	FP200-S
Pumping medium	lubricants up to NLGI class 3	lubricants up to NLGI class 3	highly viscous and solvent-free media	highly viscous and solvent-free media
Displacement/ double stroke	19 cm ³	79 cm ³	79 cm ³	79 cm ³ /double stroke
Conveying capacity	1140 cm ³ /min	4740 cm ³ /min at 60 double strokes/min	4740 cm ³ /min at 60 double strokes/min	4740 cm ³ /min at 60 double strokes/min
Transmisson	25:1	24:1 (FP050-24); 45:1 (FP050-45)	24:1 (FP200-24-T); 45:1 (FP200-45-T)	24:1 (FP200-24-S); 45:1 (FP200-45-S)
Diameter follower plate	customized	customized	530 mm	530 mm (FP200-24-S); 360 mm (storage unit)
Max. container dimensions	Ø 420 mm; height 670 mm	Ø 420 mm; height 670 mm	200 l standard barrel	200 l standard barrel
	more	more	more	more



HIGH PRESSURE BARREL PUMP FP001

DP-F-002-000049 // transmission ratio 25:1



APPLICATION

The high pressure barrel pump FP001 is suitable for pumping lubricants up to NLGI class 3.

DESCRIPTION

All D+P high pressure barrel pumps are developed in-house and are subject to extremely strict quality control. In-house production ensures optimal and technically perfect adaptation to customer requirements at all times.

ADVANTAGES

Our barrel pumps are characterized by high product quality, reliability and long service life. Application of high pressure barrel pumps with follower plate ensures optimal emptying of the barrels. In addition, in contrast to manual emptying, there is no contamination around the barrel.

TECHNICAL DATA

Pump data

Operating pressure	2–6 bar
Pumping medium	lubricants up to NLGI class 3
Displacement/double stroke	19 cm ³
Conveying capacity	1140 cm ³ /min
Delivery pressure	100 bar
Transmission ratio	25:1

Compressed air supply

Nominal supply pressure	4.5 bar
Compressed air quality	dried, filtered, oil-free
Compressed air requirement at 4 bar	max. 180 l/min
Compressed air connection	G 1/4"

Technical dimensions (barrel pump)

Depth	350 mm
Width	300 mm
Height	546 mm
Height extended	801 mm

Follower plate (specially adapted to the container)

Diameter follower plate	customized
Seal diameter	customized
Material thickness	4 mm
Material wiper rings	Vulkollan
Max. container dimensions	1 kg can, height 200 mm

Electrical connection indicator light

Connection values	230 V/50 Hz
-------------------	-------------

Environmental conditions

Temperature	10–40 °C
Humidity	50– max. 70 %
Installation conditions	flat industrial floor



HIGH PRESSURE BARREL PUMP FP015

DP-F-002-000050 // transmission ratio 25:1



APPLICATION

The high pressure barrel pump FP015 is suitable for pumping lubricants up to NLGI class 3.

DESCRIPTION

All D+P high pressure barrel pumps are developed in-house and are subject to extremely strict quality control. In-house production ensures optimal and technically perfect adaptation to customer requirements at all times.

ADVANTAGES

Our barrel pumps are characterized by high product quality, reliability and long service life. Application of high pressure barrel pumps with follower plate ensures optimal emptying of the barrels. In addition, in contrast to manual emptying, there is no contamination around the barrel.

TECHNICAL DATA

Pump data

Operating pressure	2–6 bar
Pumping medium	lubricants up to NLGI class 3
Displacement/double stroke	19 cm ³
Conveying capacity	1140 cm ³ /min
Delivery pressure	100 bar
Transmission ratio	25:1

Compressed air supply

Nominal supply pressure	4.5 bar
Compressed air quality	dried, filtered, oil-free
Compressed air requirement at 4 bar	max. 180 l/min
Compressed air connection	G 1/4"

Technical dimensions (barrel pump)

Depth	380 mm
Width	475 mm
Height	584 mm
Height extended	964 mm

Follower plate (specially adapted to the container)

Diameter follower plate	customized
Seal diameter	customized
Material thickness	6 mm
Material wiper rings	Vulkollan
Max. container dimensions	Ø 335 mm; height 360 mm

Electrical connection indicator light

Connection values	230 V/50 Hz
-------------------	-------------

Environmental conditions

Temperature	10–40 °C
Humidity	50– max. 70 %
Installation conditions	flat industrial floor



HIGH PRESSURE BARREL PUMP FP045

DP-F-002-000051 // transmission ratio 25:1



APPLICATION

The FP045 high pressure barrel pump is suitable for pumping lubricants up to NLGI class 3.

DESCRIPTION

All D+P high pressure barrel pumps are developed in-house and are subject to extremely strict quality control. In-house production ensures optimal and technically perfect adaptation to customer requirements at all times.

ADVANTAGES

Our barrel pumps are characterized by high product quality, reliability and long service life. Application of high-pressure barrel pumps with follower plate ensures optimal emptying of the barrels. In addition, in contrast to manual emptying, there is no contamination around the barrel.

TECHNICAL DATA

Pump data

Operating pressure	2–6 bar
Pumping medium	lubricants up to NLGI class 3
Displacement/double stroke	19 cm ³
Conveying capacity	1140 cm ³ /min
Delivery pressure	100 bar
Transmission ratio	25:1

Compressed air supply

Nominal supply pressure	4.5 bar
Compressed air quality	dried, filtered, oil-free
Compressed air requirement at 4 bar	max. 180 l/min
Compressed air connection	G 1/4"

Technical dimensions (barrel pump)

Depth	535 mm
Width	933 mm
Height	1443 mm
Height extended	2143 mm

Follower plate (specially adapted to the container)

Diameter follower plate	customized
Seal diameter	customized
Material thickness	6 mm
Material wiper rings	Vulkollan
Max. container dimensions	Ø 420 mm; height 670 mm

Electrical connection indicator light

Connection values	230 V/50 Hz
-------------------	-------------

Environmental conditions

Temperature	10–40 °C
Humidity	50– max. 70 %
Installation conditions	flat industrial floor



HIGH PRESSURE BARREL PUMP FP045-T

DP-F-002-000052 // transmission ratio 25:1



Image similar

APPLICATION

The high pressure barrel pump FP045-T is suitable for uninterrupted pumping of lubricants up to NLGI class 3.

DESCRIPTION

The tandem version of the FP045 enables uninterrupted production: the automatic switchover from pump A to B in the case of a tandem barrel pump ensures material conveyance without interruption.

All D+P high pressure barrel pumps are developed in-house and are subject to extremely strict quality control. In-house production ensures optimal and technically perfect adaptation to customer requirements at all times.

ADVANTAGES

Our barrel pumps are characterized by high product quality, reliability and long service life. Application of high pressure barrel pumps with follower plate ensures optimal emptying of the barrels. In addition, in contrast to manual emptying, there is no contamination around the barrel.

TECHNICAL DATA

Pump data

Operating pressure	2–6 bar
Pumping medium	lubricants up to NLGI class 3
Displacement/double stroke	19 cm ³
Conveying capacity	1140 cm ³ /min
Delivery pressure	100 bar
Transmission ratio	25:1

Compressed air supply

Nominal supply pressure	4.5 bar
Compressed air quality	dried, filtered, oil-free
Compressed air requirement at 4 bar	max. 180 l/min
Compressed air connection	G 1/4"

Technical dimensions (barrel pump)

Depth	624 mm
Width	1972 mm
Height	1443 mm
Height extended	2143 mm

Follower plate (specially adapted to the container)

Diameter follower plate	customized
Seal diameter	customized
Material thickness	6 mm
Material wiper rings	Vulkollan
Max. container dimensions	Ø 420 mm; height 670 mm

Electrical connection indicator light

Connection values	230 V/50 Hz
-------------------	-------------

Environmental conditions

Temperature	10–40 °C
Humidity	50– max. 70 %
Installation conditions	flat industrial floor



HIGH PRESSURE BARREL PUMP FP050

DP-F-002-000040 // FP050-24 // transmission ratio 24:1
 DP-F-002-000041 // FP050-45 // transmission ratio 45:1



APPLICATION

The FP050 high pressure barrel pump is suitable for pumping lubricants up to NLGI class 3.

DESCRIPTION

All D+P high pressure barrel pumps are developed in-house and are subject to extremely strict quality control. In-house production ensures optimal and technically perfect adaptation to customer requirements at all times.

ADVANTAGES

Our barrel pumps are characterized by high product quality, reliability and long service life. Application of high-pressure barrel pumps with follower plate ensures optimal emptying of the barrels. In addition, in contrast to manual emptying, there is no contamination around the barrel.

TECHNICAL DATA

Pump data

Operating pressure	2–6 bar
Pumping medium	highly viscous and solvent-free media
Displacement/double stroke	79 cm ³
Conveying capacity	4740 cm ³ /min at 60 double strokes/min
Delivery pressure	96 bar (FP050-24); 180 bar (FP050-45)
Transmission ratio	24:1 (FP050-24); 45:1 (FP050-45)
Sound level at 4 bar	73 dB

Compressed air supply

Nominal supply pressure	5 bar
Compressed air quality	dried, filtered, oil-free
Compressed air requirement at 4 bar	556.8 l/min (FP050-24); 914.2 l/min (FP050-45)
Compressed air connection	R 1/4" (coupling plug nominal width 7.2)

Technical dimensions (barrel pump)

Depth	535 mm
Width	934 mm
Height	1443 mm
Height extended	2143 mm

Follower plate (specially adapted to the container)

Diameter follower plate	customized
Seal diameter	customized
Material thickness	6 mm
Material wiper rings	Vulkollan
Max. container dimensions	Ø 420 mm; height 670 mm

Electrical connection indicator light

Connection values	230 V/50 Hz
-------------------	-------------

Environmental conditions

Temperature	10–40 °C
Humidity	50– max. 70 %
Installation conditions	flat industrial floor



HIGH PRESSURE BARREL PUMP FP050-T

DP-F-002-000042 // FP050-24-T // transmission ratio 24:1
DP-F-002-000043 // FP050-45-T // transmission ratio 45:1

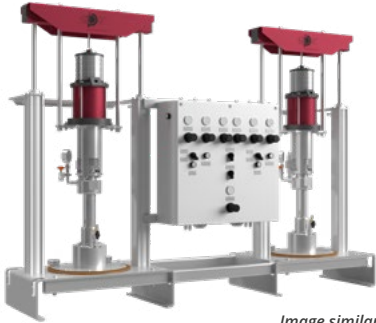

Image similar

APPLICATION

The FP050-T high pressure barrel pump is suitable for continuous pumping of high viscosity and solvent free media.

DESCRIPTION

The tandem version of the FP050 enables continuous production: the automatic switchover from pump A to B in the case of a tandem barrel pump ensures material conveyance without interruption.

All D+P high pressure barrel pumps are developed in-house and are subject to extremely strict quality control. In-house production ensures optimal and technically perfect adaptation to customer requirements at all times.

ADVANTAGES

Our barrel pumps are characterized by high product quality, reliability and long service life. The use of high-pressure barrel pumps with follower plate ensures optimal emptying of the barrels. In addition, in contrast to manual emptying, there is no contamination around the barrel.

TECHNICAL DATA

Pump data

Operating pressure	2–6 bar
Pumping medium	highly viscous and solvent-free media
Displacement/double stroke	79 cm ³
Conveying capacity	4740 cm ³ /min at 60 double strokes/min
Delivery pressure	96 bar (FP050-24-T); 180 bar (FP050-45-T)
Transmission ratio	24:1 (FP050-24-T); 45:1 (FP050-45-T)
Sound level at 4 bar	73 dB

Compressed air supply

Nominal supply pressure	5 bar
Compressed air quality	dried, filtered, oil-free
Compressed air requirement at 4 bar	556.8 l/min (FP050-24-T); 991.2 l/min (FP050-45-T)
Compressed air connection	R 1/4" (coupling plug nominal width 7.2)

Technical dimensions (barrel pump)

Depth	624 mm
Width	1972 mm
Height	1443 mm
Height extended	2143 mm

Follower plate (specially adapted to the container)

Diameter follower plate	customized
Seal diameter	customized
Material thickness	6 mm
Material wiper rings	Vulkollan
Max. container dimensions	Ø 420 mm; height 670 mm

Electrical connection indicator light

Connection values	230 V/50 Hz
-------------------	-------------

Environmental conditions

Temperature	10–40 °C
Humidity	50– max. 70 %
Installation conditions	flat industrial floor



HIGH PRESSURE BARREL PUMP FP200

DP-F-002-000044 // FP200-24 // transmission ratio 24:1
 DP-F-002-000045 // FP200-45 // transmission ratio 45:1



APPLICATION

The high pressure barrel pump FP200 is suitable for pumping high viscosity and solvent free media.

DESCRIPTION

All D+P high pressure barrel pumps are developed in-house and are subject to extremely strict quality control. In-house production ensures optimal and technically perfect adaptation to customer requirements at all times.

ADVANTAGES

Our barrel pumps are characterized by high product quality, reliability and long service life. Application of high pressure barrel pumps with follower plate ensures optimal emptying of the barrels. In addition, in contrast to manual emptying, there is no contamination around the barrel.

TECHNICAL DATA

Pump data

Operating pressure	2–6 bar
Pumping medium	highly viscous and solvent-free media
Displacement/double stroke	79 cm ³
Conveying capacity	4740 cm ³ /min at 60 double strokes/min
Delivery pressure	96 bar (FP200-24); 180 bar (FP200-45)
Transmission ratio	24:1 (FP200-24); 45:1 (FP200-45)
Sound level at 4 bar	73 dB

Compressed air supply

Nominal supply pressure	5 bar
Compressed air quality	dried, filtered, oil-free
Compressed air requirement at 4 bar	556.8 l/min (FP200-24); 991.2 l/min (FP200-45)
Compressed air connection	R 1/4" (coupling plug nominal width 7.2)

Technical dimensions (barrel pump)

Depth	735 mm
Width	1238 mm
Height	1786 mm
Height extended	2786 mm

Follower plate (specially adapted to the container)

Diameter follower plate	530 mm
Seal diameter	480 x 45 mm
Material wiper rings	neoprene
Max. container dimensions	200 l standard barrel

Electrical connection indicator light

Connection values	230 V/50 Hz
-------------------	-------------

Environmental conditions

Temperature	10–40 °C
Humidity	50– max. 70 %
Installation conditions	flat industrial floor



HIGH PRESSURE BARREL PUMP FP200-T

DP-F-002-000046 // FP200-24-T // transmission ratio 24:1
DP-F-002-000047 // FP200-45-T // transmission ratio 45:1



APPLICATION

The FP200-T high pressure barrel pump is suitable for uninterrupted pumping of high viscosity and solvent free media.

DESCRIPTION

The tandem version of the FP200 enables continuous production: the automatic switchover from pump A to B in the case of a tandem barrel pump ensures material conveyance without interruption.

All D+P high pressure barrel pumps are developed in-house and are subject to extremely strict quality control. In-house production ensures optimal and technically perfect adaptation to customer requirements at all times.

ADVANTAGES

Our barrel pumps are characterized by high product quality, reliability and long service life. The use of high-pressure barrel pumps with follower plate ensures optimal emptying of the barrels. In addition, in contrast to manual emptying, there is no contamination around the barrel.

TECHNICAL DATA

Pump data

Operating pressure	2–6 bar
Pumping medium	highly viscous and solvent-free media
Displacement/double stroke	79 cm ³
Conveying capacity	4740 cm ³ /min at 60 double strokes/min
Delivery pressure	96 bar (FP200-24-T); 180 bar (FP200-45-T)
Transmission ratio	24:1 (FP200-24-T); 45:1 (FP200-45-T)
Sound level at 4 bar	73 dB

Compressed air supply

Nominal supply pressure	5 bar
Compressed air quality	dried, filtered, oil-free
Compressed air requirement at 4 bar	556.8 l/min (FP200-24-T); 991.2 l/min (FP200-45-T)
Compressed air connection	R 1/4" (coupling plug nominal width 7.2)

Technical dimensions (barrel pump)

Depth	755 mm
Width	2572 mm
Height	1786 mm
Height extended	2786 mm

Follower plate (specially adapted to the container)

Diameter follower plate	530 mm
Seal diameter	480 x 45 mm
Material wiper rings	neoprene
Max. container dimensions	200 l standard barrel

Electrical connection indicator light

Connection values	230 V/50 Hz
-------------------	-------------

Environmental conditions

Temperature	10–40 °C
Humidity	50– max. 70 %
Installation conditions	flat industrial floor



HIGH PRESSURE BARREL PUMP FP200-S

DP-F-002-000048 // FP200-24-S // transmission ratio 24:1
 DP-F-002-000055 // FP200-45-S // transmission ratio 45:1



APPLICATION

The FP200-S high pressure barrel pump is suitable for uninterrupted pumping of high viscosity and solvent free media.

DESCRIPTION

Advantage of the FP200-S high-pressure barrel pump with accumulator over the FP200-T high-pressure tandem barrel pump: only one 200-liter barrel is required > the medium is subjected to only a short cycle time

The FP200-S high-pressure barrel pump works in the same way as the FP200-24 (or FP200-45) high-pressure barrel pump.

Thanks to the storage unit, from which the medium is automatically pumped when the barrel is changed, uninterrupted pumping of the medium is possible.

All D+P high pressure barrel pumps are developed in-house and are subject to extremely strict quality control. In-house production ensures optimal and technically perfect adaptation to customer requirements at all times.

ADVANTAGES

Our barrel pumps are characterized by high product quality, reliability and long service life. Application of high-pressure barrel pumps with follower plate ensures optimal emptying of the barrels. In addition, in contrast to manual emptying, there is no contamination around the drum.

TECHNICAL DATA

Pump data

Operating pressure	2–6 bar (depending on viscosity)
Pumping medium	highly viscous, solvent-free media
Displacement/double stroke	79 cm ³ /double stroke
Conveying capacity	4740 cm ³ /min at 60 double strokes/min
Delivery pressure	96 bar (FP200-24-S); 180 bar (FP200-45-S)
Transmission ratio	24:1 (FP200-24-S); 45:1 (FP200-45-S)
Sound level at 4 bar	73 dB

Compressed air supply

Nominal supply pressure	5 bar
Compressed air quality	dried, filtered, oil-free
Compressed air requirement at 4 bar	556.8 l/min (FP200-24-S); 991.2 l/min (FP200-45-S) at 60 double strokes/min
Compressed air connection	R ¼" (coupling plug nominal width 7.2)

Technical dimensions (barrel pump)

Depth	811 mm
Width	1752 mm
Height	1786 mm (FP200-24-S); 1443 mm (storage unit)
Height extended	2786 mm (FP200-24-S); 2143 mm (storage unit)

Follower plate (specially adapted to the container)

Diameter follower plate	530 mm (FP200-24-S); 360 mm (storage unit)
Seal diameter	480 x 45 mm (FP200-24-S); 398 mm (storage unit)
Material thickness	neoprene (FP200-24-S); Vulkollan (storage unit)
Material wiper rings	200 l standard barrel (FP200-24-S); 50 l stainless steel barrel (storage unit)



REPORTING UNITS



BARREL EMPTY AND REFILL MESSAGE FP001

DP-F-003-000076

Proximity switches for barrel refill/empty signal with holder. When the fill level is low, a refill message is issued, or an empty message is issued after the container has been completely emptied.

▶ ▶ ▶ **FP001**



BARREL EMPTY AND REFILL MESSAGE FP015 UP

DP-F-003-000001

Proximity switches for barrel refill/empty signal with holder for each pump. When the fill level is low, a refill message is issued, or an empty message is issued after the container has been completely emptied.

▶ ▶ ▶ **FP015, FP045, FP045-T, FP050, FP050-T, FP200, FP200-T, FP200-S**



ACOUSTIC EMPTY SIGNAL FOR BARREL PUMP FP001

DP-F-003-000010

With pump stop function, pneumatic whistle unit and throttle valve for volume control. When the fill level is low, the pump is automatically switched off, thus preventing air from being sucked in. The acoustic empty signal indicates that the barrel pump has been switched off and is mounted on the barrel pump.

▶ ▶ ▶ **FP001**



ACOUSTIC EMPTY SIGNAL FOR BARREL PUMP FP015 UP

DP-F-003-000014

Throttle valve for volume control of a pneumatic whistle unit and a pump stop function that automatically switches off the pump when the fill level is low, thus preventing air from being drawn in. The acoustic empty signal indicates that the barrel pump has been switched off.

▶ ▶ ▶ **FP015, FP045, FP045-T, FP050, FP050-T, FP200, FP200-T, FP200-S**



REPORTING UNITS



BARREL PUMP INDICATOR LIGHT

DP-F-003-000011 // for single pumps

DP-F-003-000018 // for tandem pumps

SIGNALS OVERVIEW

Green light: all production conditions fulfilled, fat is conveyed

Yellow light: barrel empty or one of the two barrels is empty, "Refill barrel" is activated

Red light: barrel empty or both barrels empty; grease is not pumped, material pressure not present.

Buzzer: Barrel empty or both barrels empty; grease is not pumped, material pressure not present

▶ ▶ ▶ FP050, FP050-T, FP200, FP200-T, FP200-S

BARREL PUMP INDICATOR LIGHT PROFINET / PROFIBUS CONTROL

DP-F-003-000030 // Profinet, for single pumps

DP-F-003-000031 // Profinet, for tandem pumps

DP-F-003-000032 // Profibus, for single pumps

DP-F-003-000033 // Profibus, for tandem pumps

The signals from the sensors are sent to the higher-level controller via Profinet. Lamps and buzzers are to be controlled by the higher-level controller.

▶ ▶ ▶ FP050, FP050-T, FP200, FP200-T, FP200-S



PRESSURE REDUCING AND SHUT-OFF UNITS



PRESSURE SWITCH

DP-K-007-000001 // type 804-10
 DP-K-007-000002 // type 804-20
 DP-K-007-000003 // type 804-100
 DP-K-007-000004 // type 804-200

Pressure switch for monitoring the material pressure in the supply line.

TECHNICAL DATA

Type	804-10	804-20	804-100	804-200
Pressure range	1–10 bar	2–20 bar	1–100 bar	2–200 bar
Compressive strength	300 bar	300 bar	600 bar	600 bar
Max. voltage	250 V	250 V	250 V	250 V
Max. current	2 A	2 A	2 A	2 A
Connection	G 1/4"	G 1/4"	G 1/4"	G 1/4"

▶▶▶ FP001, FP015, FP045, FP045-T, FP050, FP050-T, FP200, FP200-T, FP200-S



PRESSURE SENSOR WITH DISPLAY

DP-K-007-000009 // type PN 7071
 DP-K-007-000010 // type PN 7070
 DP-K-007-000011 // type PN 7093
 DP-K-007-000012 // type PN 7094

Electronic pressure sensor with display for monitoring the material pressure in the supply line.

- ▶ 2 switching outlets (make/break contact parameterizable)
- ▶ 2 output signals (switching signal, IO-Link configurable)
- ▶ 4-digit alphanumeric display (digital display) with red-green alternating display

TECHNICAL DATA

Type	PN 7071	PN 7070	PN 7093	PN 7094
Pressure range	0–250 bar	0–400 bar	0–25 bar	–1–10 bar
Compressive strength	800 bar	800 bar	150 bar	75 bar
Voltage	18–30 V	18–30 V	18–30 V	18–30 V
Max. current	150 mA	150 mA	150 mA	35 mA
Connection	G 1/4"	G 1/4"	G 1/4"	G 1/4"
Electrical connection	plug connection 1x M12 A-coded			

▶▶▶ FP001, FP015, FP045, FP045-T, FP050, FP050-T, FP200, FP200-T, FP200-S



PRESSURE REDUCING AND SHUT-OFF UNITS



STOPCOCK WITH CONNECTION ADAPTER KH HD

DP-D-003-000001 // G 1/4"
DP-D-003-000008 // G 1/2"

Shut-off valve for manual shut-off of the material line.
Type: KH HD Ball cock high pressure

TECHNICAL DATA

Connection thread	G 1/4"	G 1/2"
Material	steel	steel
Max. operating pressure	500 bar	500 bar

▶ ▶ ▶ FP001, FP015, FP045, FP045-T, FP050, FP050-T, FP200, FP200-T, FP200-S



SHUT-OFF AND VENT COCK WITH CONNECTION ADAPTER KH HD

DP-D-003-000002

Shut-off valve for manual shut-off and venting of the material line.
Type: KH HD Ball cock high pressure

TECHNICAL DATA

Connection thread	G 1/4"
Material	steel
Max. operating pressure	300 bar

▶ ▶ ▶ FP001, FP015, FP045, FP045-T, FP050, FP050-T, FP200, FP200-T, FP200-S



PRESSURE REDUCING AND SHUT-OFF UNITS



PRESSURE REGULATING VALVE WITH INLET AND OUTLET PRESSURE GAUGES

DP-K-002-000056 // type C-450.00.24
DP-K-002-000057 // type C-450.00.25
DP-K-002-000064 // type C-450.00.13
DP-K-002-000062 // type C-450.00.04 (carbide version)
DP-K-002-000063 // type 1013168 (carbide version)

The Pressure regulating valve is suitable for reducing the material pressure to the required working pressure and for leveling out pressure fluctuations in the material supply of greases, oils and pastes. This ensures an absolutely uniform material flow during metering application.

Standard version with inlet and outlet pressure gauge. Optional accessories: Shut-off and vent cock, pressure switch, pressure sensor.

TECHNICAL DATA

Type	C-450.00.24	C-450.00.25	C-450.00.13	C-450.00.04	1013168
Inlet pressure	20-250 bar	20-250 bar	30-400 bar	20-250 bar	20-250 bar
Outlet pressure	12-100 bar	6-50 bar	15-150 bar	6-50 bar	12-100 bar

▶▶▶ FP001, FP015, FP045, FP045-T, FP050, FP050-T, FP200, FP200-T, FP200-S



PRESSURE REDUCING AND SHUT-OFF UNITS



PRESSURE REGULATING VALVE DRV04

DP-D-012-000001 // DRV04-25-2M
 DP-D-012-000002 // DRV04-45-2M
 DP-D-012-000003 // DRV04-80-2M
 DP-D-012-000012 // DRV04-200-2M

APPLICATION

The Pressure regulating valve is suitable for reducing the material pressure to the required working pressure and for leveling out pressure fluctuations in the material supply of greases, oils and pastes. This ensures an absolutely uniform material flow during metering application.

DESCRIPTION

The Pressure regulating valve consists of a basic body and a pressure unit (sealing ball and seat made of hard metal, as well as a high-quality spring assembly). Standard version with inlet and outlet pressure gauge. Optional accessories: Shut-off and vent cock, pressure switch, pressure sensor.

ADVANTAGES

- ▶ Very low wear due to precisely guided hard metal ball and hard metal seat
- ▶ Seal package can be changed quickly and easily without dismantling the unit from the plant
- ▶ Simple pressure adjustment
- ▶ Piston movement optically visible and measurable
- ▶ Flexible mounting options

TECHNICAL DATA

Type	DRV04-25	DRV04-45	DRV04-80	DRV04-200
Weight	approx. 2.0 kg			
Material conditions				
Inlet pressure	max. 250 bar			
Outlet pressure	3–25 bar	6–45 bar	12–80 bar	30–200 bar
Max. ratio between inlet and outlet pressure	5:1			
Connection material input	G 1/4" female thread			
Connection material outlet	G 1/4" female thread			
Permissible medium	NLGI class 0–3 (greases, oils, pastes)			
Environmental conditions				
Temperature	10–50 °C			
Humidity	50– max. 70 %			

▶ ▶ ▶ FP001, FP015, FP045, FP045-T, FP050, FP050-T, FP200, FP200-T, FP200-S



HIGH PRESSURE FILTERS AND MIXING PIPES



HIGH PRESSURE FILTER

DP-K-010-000001 // G 1/2"
DP-K-010-000003 // G 1/4"

High pressure filter housing with filter element for dirt particle filtration, with visual and electrical contamination indicator.

TECHNICAL DATA

Connection	G 1/2"	G 1/4"
Max. nominal pressure	400 bar	400 bar
Switching pressure of opt./electr.	p 5 bar ± 10 %	p 5 bar ± 10 %
Contact type	N/O contact / N/C contact	N/O contact / N/C contact
Max. voltage	250 V	250 V
Max. current	2.5 A	2.5 A

▶▶▶ FP001, FP015, FP045, FP045-T, FP050, FP050-T, FP200, FP200-T, FP200-S



FILTER ELEMENT (SPARE PART)

DP-K-010-000002 // G 1/2"
DP-K-010-000004 // G 1/4"

For high pressure filters.

▶▶▶ FP001, FP015, FP045, FP045-T, FP050, FP050-T, FP200, FP200-T, FP200-S



HIGH PRESSURE FILTERS AND MIXING PIPES



STATIC MIXING PIPE TYPE T

DP-K-009-000001 // G 1/4"
DP-K-009-000002 // G 1/2"
DP-K-009-000005 // G 3/8"

Air pockets are cut up several times by the individual spiral mixing elements and efficiently reduced in size.

TECHNICAL DATA

Connection external thread	G 1/4", G 1/2", G 3/8"
Length	430 mm
Max. pressure	250 bar
Operating temperature	10–80 °C

▶▶▶ FP001, FP015, FP045, FP045-T, FP050, FP050-T, FP200, FP200-T, FP200-S



STATIC MIXING PIPE TYPE TG

DP-K-009-000003 // G 1/4"
DP-K-009-000004 // G 1/2"
DP-K-009-000006 // G 3/8"

Air pockets are cut up several times by the individual spiral and grid mixing elements and efficiently reduced in size.

TECHNICAL DATA

Connection external thread	G 1/4", G 1/2", G 3/8"
Length	430 mm
Max. pressure	250 bar
Operating temperature	10–80 °C

▶▶▶ FP001, FP015, FP045, FP045-T, FP050, FP050-T, FP200, FP200-T, FP200-S



FOLLOWER PLATES AND SEALING RUBBER SETS



FOLLOWER PLATE WITH VULKOLLAN SEAL

DP-F-003-000003 // up to 260 mm diameter
DP-F-003-000004 // from 260 mm diameter
DP-F-003-000037 // double, up to 260 mm diameter
DP-F-003-000038 // double, from 260 mm diameter

The follower plate is specially adapted to the container. The seal strips directly along the inner wall of the container and thus ensures optimum and residue-free emptying. The following container dimensions are required for the adaptation:

- ▶ Inner Ø bottom
- ▶ Inner Ø top

▶ ▶ ▶ FP001, FP015, FP045, FP045-T, FP050, FP050-T



REPLACEMENT VULKOLLAN GASKET FOR FOLLOWER PLATE

DP-F-003-000006 // up to 260 mm diameter
DP-F-003-000007 // from 260 mm diameter

▶ ▶ ▶ FP001, FP015, FP045, FP045-T, FP050, FP050-T



FOLLOWER PLATE FOR 200 LITER STANDARD BARREL

DP-F-003-000005
DP-F-003-000028

With 2 neoprene seals.

▶ ▶ ▶ FP200, FP200-T, FP200-S



SEALING RUBBER KIT FOR FOLLOWER PLATE 200 LITER STANDARD BARREL

DP-F-003-000017
DP-F-003-000029

With 2 neoprene seals.

▶ ▶ ▶ FP200, FP200-T, FP200-S



MATERIAL PRESSURE RELIEF



MATERIAL PRESSURE RELIEF

DP-F-003-000024 // manual
DP-F-003-000025 // pneumatic

The material pressure relief after switching off the barrel pump prevents segregation of base oil and thickener in media that are not pressure-stable (oil separation).

▶▶▶ FP015, FP045, FP045-T, FP050, FP050-T, FP200, FP200-T, FP200-S



MANUAL SLIDE VALVE HS14

DP-K-012-000001

For manually shutting off the compressed air supply to the barrel pump and activating the material pressure relief.

▶▶▶ FP015, FP045, FP045-T, FP050, FP050-T, FP200, FP200-T, FP200-S



SWITCH-ON/PRESSURE BUILD-UP VALVE HEE- $\frac{3}{8}$

DP-K-012-000002

For shutting off the compressed air supply by the station/line control, deactivating the barrel pump and activating the material pressure relief.

▶▶▶ FP015, FP045, FP045-T, FP050, FP050-T, FP200, FP200-T, FP200-S



PNEUMATIC BALL COCK

For controlled shut-off of the material line.

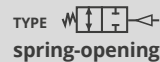
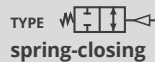
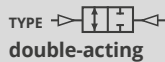

VARIANTS

- DP-K-008-000001 // KH14HD P, double-acting
- DP-K-008-000002 // KH14HD P FO
- DP-K-008-000003 // KH14HD P FS
- DP-K-008-000004 // KH38HD P, double-acting
- DP-K-008-000005 // KH38HD P FO
- DP-K-008-000006 // KH38HD P FS

* Abbreviations:

KH = ball cock // P = pneumatic // FO = spring-opening // FS = spring-closing // 14 = G 1/4", 38 = G 3/8"

▶▶▶ FP015, FP045, FP045-T, FP050, FP050-T, FP200, FP200-T, FP200-S



GENERAL ACCESSORIES



GREASE DISTRIBUTOR 5-FOLD INCL. CONNECTION NIPPLE

DP-D-003-000006 // G 1/4"
DP-D-003-000007 // G 1/8"
DP-D-003-000024 // G 1/2"

5-fold grease distributor with double nipple for optimum distribution of the material feed. The outlets that are not required can be closed off in a pressure-tight manner using the screw fittings supplied.

VARIANTS

G 1/4" = internal & external thread
G 1/8" = internal & external thread
G 1/2" = internal & external thread

▶▶▶ FP001, FP015, FP045, FP045-T, FP050, FP050-T, FP200, FP200-T, FP200-S



SUPERSTRUCTURE FOR BARREL PUMP OPERATING UNIT

DP-F-003-000012 // single
DP-F-003-000022 // tandem
DP-F-003-000023 // FP200-S

Frame made of aluminum profile for receiving and mounting the barrel pump accessories and the barrel pump operating unit.

▶▶▶ FP045, FP045-T, FP050, FP050-T, FP200, FP200-T, FP200-S



VENT HOSE FOR BARREL PUMPS

DP-F-003-000019

Mounted on the vent cock of the barrel pump suction pipe.

TECHNICAL DATA

Length	1 m
Max. pressure	20 °C > 800 bar, 60 °C > 450 bar
Bending radius at 20 °C	> 20 mm
Connection	G 1/8"

▶▶▶ FP001, FP015, FP045, FP045-T, FP050, FP050-T, FP200, FP200-T, FP200-S



GENERAL ACCESSORIES

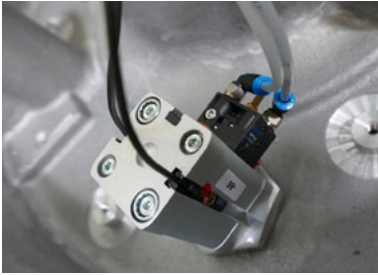

DIRECT SWITCHOVER/STOP AUTOMATIC

DP-F-003-000016

The automatic changeover for tandem barrel pumps is mounted in the follower plate. After the first barrel has been completely emptied (on contact with the bottom), there is an automatic switchover (automatic changeover) to the second pump mechanism. When both barrels are completely emptied, the pump switches off automatically (automatic stop), thus preventing air from being sucked in.

▶ ▶ ▶ FP200-T



DRY RUN SAFETY

DP-F-003-000020 // single
DP-F-003-000021 // tandem

The valve for automatic shut-off of the compressed air supply is triggered when an increased conveying speed is detected. This prevents unwanted emptying of the container, e.g. if the material line breaks.

▶ ▶ ▶ FP050, FP050-T, FP200, FP200-T, FP200-S



CHECK VALVE PACKAGE

DP-F-003-000008 // G 3/8"
DP-F-003-000027 // G 1/2"

Prevents the medium from flowing back into the inactive pump. The valve closes automatically at the pump outlet against the direction of flow.

▶ ▶ ▶ FP050-T, FP200-T



WHEELS FOR BARREL PUMP FP050

DP-F-003-000015

Set of two fixed and two swivel castors with parking brake.

▶ ▶ ▶ FP050



GENERAL ACCESSORIES



ROTATING COUPLING

DP-K-008-000007 // G 1/4"
DP-K-008-000008 // G 1/8"

Flexible connection between high-pressure hose and components. The coupling prevents torsion of the hose or unwanted opening of fittings and can be rotated in any direction.

▶▶▶ FP001, FP015, FP045, FP045-T, FP050, FP050-T, FP200, FP200-T, FP200-S

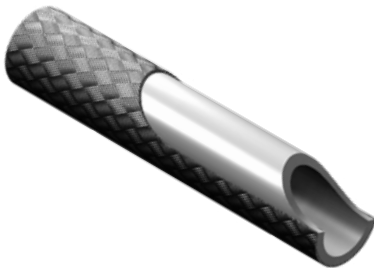

HIGH PRESSURE TEFLON HOSE

DP-D-002-000003 // G 1/8"
DP-D-002-000004 // G 1/4"
DP-D-002-000005 // G 3/8"

The high pressure teflon hose is used for medium pressure applications with hydraulic fluids at high temperatures as well as for aggressive media for the chemical industry, surface technology and 2-component plants. It is suitable for continuous temperatures from -50 °C to +150 °C and +230 °C at operating pressures up to 2 mpa and is resistant to almost all hydraulic fluids and chemicals.

Inner layer material: polytetrafluoroethylene

TECHNICAL DATA

Connection thread	Outer Ø	Max. operating pressure	Min. bending radius
G 3/8"	13.0 mm	175 bar	120 mm
G 1/8"	9.5 mm	240 bar	75 mm

▶▶▶ FP001, FP015, FP045, FP045-T, FP050, FP050-T, FP200, FP200-T, FP200-S



GENERAL ACCESSORIES



HIGH PRESSURE HOSE

- DP-D-002-000001 // G 1/4"
- DP-D-002-000002 // G 1/8"
- DP-D-002-000006 // G 3/8"
- DP-D-002-000008 // G 1/2"

The high pressure hose is used for demanding medium-pressure hydraulic applications and for media such as hydraulic fluids, mineral oil or water-glycol based, lubricating oils, air and water. It is suitable for the temperature range from -40 to +100 °C.

Inner layer material: nitrile
Compression member: Two high-tensile steel mesh Applications

TECHNICAL DATA

Connection	Outer Ø	Max. operating pressure	Min. bending radius
G 1/4"	13.4 mm	425 bar	75 mm
G 1/8"	8.75 mm	450 bar	20 mm
G 3/8"	17.2 mm	350 bar	90 mm
G 1/2"	20.4 mm	310 bar	130 mm

▶▶▶ FP001, FP015, FP045, FP045-T, FP050, FP050-T, FP200, FP200-T, FP200-S



PNEUMATIC GREASE CYLINDER

DP-F-006-000001



APPLICATION

For decentralized supply of grease applications without long hose runs.
Pneum. working pressure: 6 bar.

ACCESSORIES

FILLING DEVICE FOR PNEUMATIC GREASE CYLINDER

DP-F-006-000002

For safe filling of the pneumatic grease cylinder by a barrel pump.
Incl. safety valve and flat-face coupling.

FLAT-FACE COUPLING PACKAGE

DP-F-006-000003

Makes it difficult for dirt and air to enter the grease cylinder as the coupling can be easily wiped clean on the smooth "flat face" surface.
Consists of sleeve and plug.



MATERIAL PRESSURE TANKS

DP-K-004-000001
 DP-K-004-000002
 DP-K-004-000003

TÜV certified material pressure tanks made of stainless steel for conveying liquid media.
 With pressure regulator, quick exhaust valve, float switch with two switching points for refill/ and empty indication and ball cocks for shutting off the lines when refilling the container.



TECHNICAL DATA			
Item number	DP-K-004-000001	DP-K-004-000002	DP-K-004-000003
Content	5 l	10 l	19,5 l
Max. operating pressure	6 bar	6 bar	6 bar
Connection	compressed air plug nipple NW 7.2	compressed air plug nipple NW 7.2	compressed air plug nipple NW 7.2
Diameter	approx. 216 mm	approx. 216 mm	approx. 216 mm
Height	approx. 250 mm	approx. 365 mm	approx. 628 mm
Weight	approx. 3 kg	approx. 4 kg	approx. 5 kg
Float switch	2 switching points	2 switching points	2 switching points

(operation only on safety extra-low voltage)

DIFFERENT VARIANTS ON REQUEST:

Pressure tanks with additional lockable pressure gauge or with Viton are available in all 3 sizes (standard: NBR seal).



MATERIAL PRESSURE TANKS ACCESSORIES



MATERIAL FILTER

DP-K-004-000004

Stainless steel material filter for filtering liquid media.
Mounted on the material pressure tank.

TECHNICAL DATA

100 Mesh	
Material	1.4305
Compressive strength	250 bar
Connection	G 1/4"



PRESSURE SWITCH TYPE 804-10 / TYPE 804-20

DP-K-007-000001 // type 804-10

DP-K-007-000002 // type 804-20

Pressure switch for monitoring the material pressure in the supply line.

TECHNICAL DATA

Type	804-10	804-20
Pressure range	1-10 bar	2-20 bar
Compressive strength	300 bar	300 bar
Max. voltage	250 V	250 V
Max. current	2 A	2 A
Connection	G 1/4"	G 1/4"



MATERIAL PRESSURE TANKS ACCESSORIES



PRESSURE SENSOR PN 7093 DIGITAL

DP-K-007-000011 // type PN 7093

Electronic pressure sensor with display for monitoring the material pressure in the supply line.

- ▶ 2 switching outlets (make/break contact parameterizable)
- ▶ 2 output signals (switching signal, IO-Link configurable)
- ▶ 4-digit alphanumeric display (digital display) with red-green alternating display

TECHNICAL DATA

Type	PN 7093
Pressure range	0–25 bar
Compressive strength	150 bar
Voltage	18–30 V
Max. current	150 mA
Connection thread	G 1/4"
Electrical connection	plug connection 1x M12 A-coded



MATERIAL FABRIC / OIL PRESSURE HOSE

DP-D-002-000007 // G 1/4"

Universal hose, resistant to a wide range of media; for mineral oil products with a max. aromatics content of 50 % and alternative fuels, such as RME (rapeseed methyl ester) or vegetable oils up to +70 °C (+158 °F).

TECHNICAL DATA

Connection thread	G 1/4"
Outer Ø	12.0 mm
Max. operating pressure	20 bar
Min. bending radius	25 mm

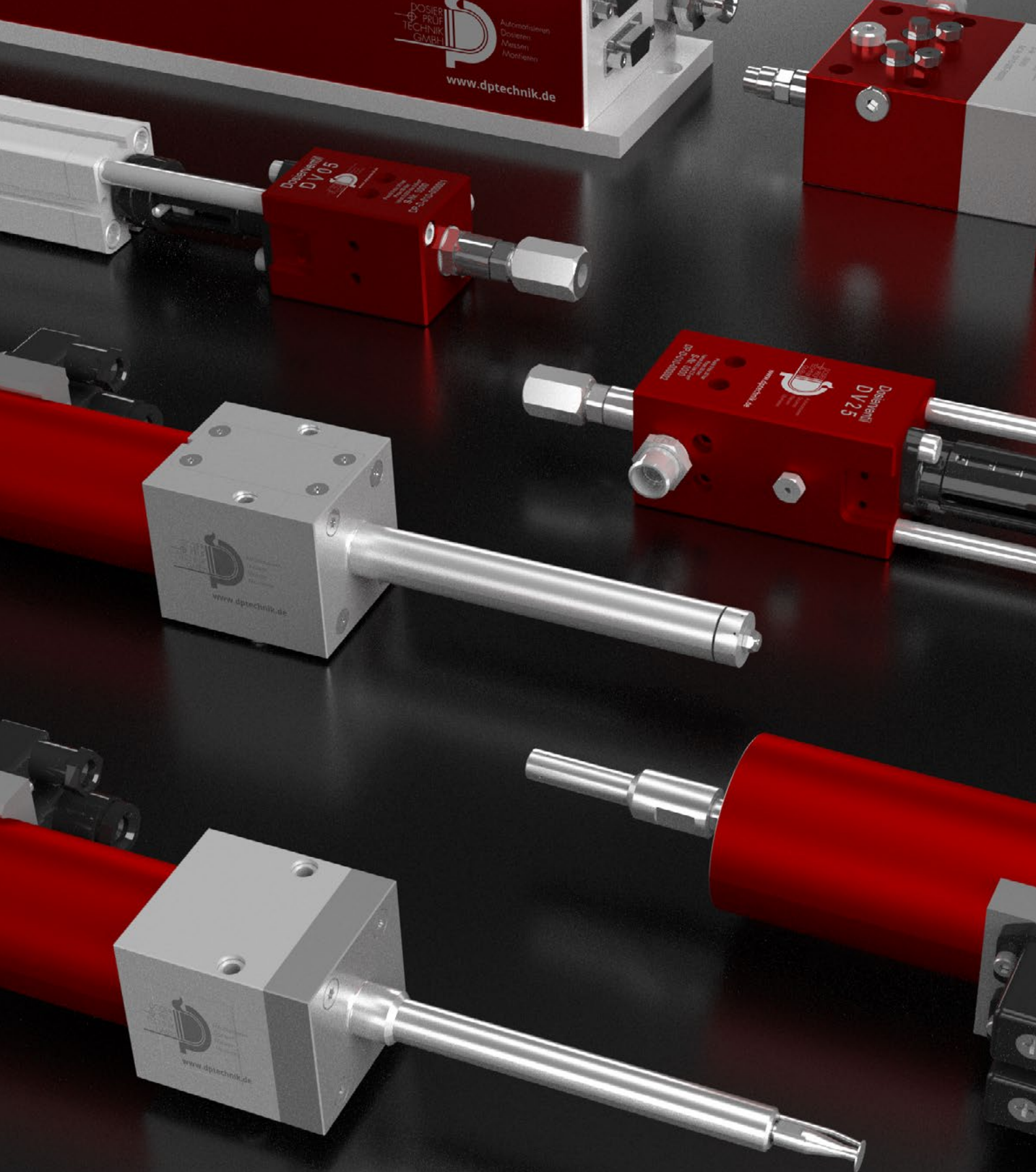

DOSIER-
PRÜF-
TECHNIK
GMBH
Automatisieren
Dosieren
Messen
Montieren
www.dptechnik.de

Dosierventil
DI 05

Dosierventil
DI 25

www.dptechnik.de

www.dptechnik.de



DOSING
APPLYING



OVERVIEW

Volumetric dosing	36
Time controlled dosing	50
Rotary greasing	65

With the dosing, greasing and application systems we have developed for surface, contour and dot application, you have a wide range of options at your disposal to make your processes more efficient and cleaner. Depending on the task at hand, greases, oils, silicones, sealants, adhesives or pastes can be applied precisely using the customized systems.

Whether you need special dispensing devices for particular challenges or are looking for high-quality universal products, our range of dispensing technology has been developed to meet the requirements of a wide variety of industries and challenges.

With our products, you get the proven reliability of an industry standard and the flexibility of a customized solution.



DOSING VALVE DV05

DP-D-010-000001

**APPLICATION**

The DV05 is suitable for volumetric dosing of low to high viscosity media in the dosing range of 0.003–0.5 cm³ and can be used for manual as well as automatic dosing processes.

DESCRIPTION

The valve consists of two structurally separate parts. This design prevents uncontrolled leakage of the medium into the pneumatic cylinder and thus prevents interference with the valve needle.

The exact dosing quantity is set via the adjusting nuts with readable quantity scale, which enables repeatable, exact and precise dosing.

The metering cycle can be controlled pneumatically by means of a 5/2 directional control valve.

ADVANTAGES

The DV05 is characterized by high reliability and low maintenance.

The modular seal package ensures fast and service-friendly maintenance in just a few steps. The seals meet the latest technological standards and ensure a long service life for the valve.

TECHNICAL DATA**Dimensions**

Weight	760 g
Width x height x depth	58 x 238 x 41 mm

Compressed air supply

Pressure	3.5–10 bar
Compressed air quality	dried, filtered, oil-free
Pneumatic connections	M5 female thread

Environmental conditions

Temperature	10–50 °C
Humidity	50– max. 70 %
Installation conditions	flat industrial floor
Sound level	<70 dB(A)

Material conditions

Material input pressure	3–30 bar
Material output pressure at 5 bar operating pressure	approx. 75 bar
Dosing speed	max. 200 ms/dosing cycle
Dosing quantity	0.003–0.5 cm ³
Connection input medium	M12x1.5 external thread
Connection output medium	G 1/4" external thread
Permissible medium	NLGI class 0–3 (greases, oils, pastes, silicones)



DOSING VALVE DV05 ACCESSORIES



STROKE MONITORING P

DP-D-010-000020

Cylinder switch with reed contact for sensing the dosing and loading position.



STROKE MONITORING K

DP-D-010-000021

Switch with inductive sensor BES00HF for sensing the dosing and loading position.



SEALING PACKAGE

DP-D-010-000040

Complete package incl. sleeve with seal set and dosing needle.



HANDLE

DP-K-002-000020 // pneumatic
DP-K-002-000021 // electric

Handle for dosing valves for manual application.
Available in electric and pneumatic versions.

PLASTIC HOSE

DP-D-002-000030 // Outer diameter 2.5 mm
DP-D-002-000031 // Outer diameter 4 mm

Pressure-resistant plastic hose for dosing valves.
Connection 1: 1/8"
Connection 2: 1/8" or M6x0,57 (e.g. for dosing head)
Length approx. 0.2 m.



MANUAL DOSING VALVE HDV05

DP-D-010-000003



APPLICATION

The HDV05 is suitable for manual, volumetric dosing of low to high viscosity media in the dosing range of 0.003–0.5 cm³.

DESCRIPTION

The manual outlet valve HDV05 is based on our proven dosing valve DV05. The pneumatic part of the dosing valve is controlled by a pneumatic 5/2-way valve. The preset quantity of medium is dispensed by actuating the trigger. The dosing speed depends on the material pressure (medium).

The design consisting of two separate parts prevents uncontrolled leakage of the medium into the pneumatic cylinder and thus prevents interference with the valve needle.

The exact dosing quantity is set via the adjusting nuts with readable quantity scale, which enables repeatable, exact and precise dosing.

The user-friendly design and the non-slip grip surface enable uncomplicated and quick handling and are ideal for use with balancers.

ADVANTAGES

The HDV05 is characterized by high reliability and low maintenance.

The modular seal package ensures fast and service-friendly maintenance in just a few steps. The seals meet the latest technological standards and ensure a long service life for the valve.

TECHNICAL DATA

Dimensions

Weight	1.36 kg
Width x height x depth	54 x 270.5 x 79 mm
Compressed air supply	
Pressure	3.5–10 bar
Compressed air quality	dried, filtered, oil-free
Pneumatic connections	M5 female thread
Environmental conditions	
Temperature	10–50 °C
Humidity	50– max. 70 %
Installation conditions	flat industrial floor
Sound level	<70 dB(A)
Material conditions	
Material input pressure	3–30 bar
Material output pressure at 5 bar operating pressure	approx. 75 bar
Dosing speed	max. 200 ms/dosing cycle
Dosing quantity	0.003–0.5 cm ³
Connection input medium	M12x1.5 external thread
Connection output medium	G 1/4" external thread
Permissible medium	NLGI class 0–3 (greases, oils, pastes, silicones)



ACCESSORIES MANUAL DOSING VALVE HDV05



STROKE MONITORING P

DP-D-010-000020

Cylinder switch with reed contact for sensing the dosing and loading position.



SEALING PACKAGE

DP-D-010-000040

Complete package incl. sleeve with seal set and dosing needle.

PLASTIC HOSE

DP-D-002-000030 // Outer diameter 2.5 mm

DP-D-002-000031 // Outer diameter 4 mm

Pressure-resistant plastic hose for dosing valves.

Connection 1: 1/8"

Connection 2: 1/8" or M6x0,57 (e.g. for dosing head)

Length approx. 0.2 m.



DOSING VALVE DV25

DP-D-010-000002



APPLICATION

The DV25 is suitable for volumetric dosing of low to high viscosity media in the dosing range of 0.02–2.5 cm³ and can be used for manual as well as automatic dosing processes.

DESCRIPTION

The valve consists of two structurally separate parts. This design prevents uncontrolled leakage of the medium into the pneumatic cylinder and thus prevents interference with the valve needle.

The exact dosing quantity is set via the adjusting nuts with readable quantity scale, which enables repeatable, exact and precise dosing.

The metering cycle can be controlled pneumatically by means of a 5/2 directional control valve.

ADVANTAGES

The DV25 is characterized by high reliability and low maintenance.

The modular seal package ensures fast and service-friendly maintenance in just a few steps. The seals meet the latest technological standards and ensure a long service life for the valve.

TECHNICAL DATA

TECHNICAL DATA	
Dimensions	
Weight	1500 g
Width x height x depth	67 x 330 x 50 mm
Compressed air supply	
Pneumatic operating pressure	3.5–10 bar
Compressed air quality	dried, filtered, oil-free
Pneumatic connections	G 1/8" female thread
Environmental conditions	
Temperature	10–50 °C
Humidity	50– max. 70 %
Installation conditions	flat industrial floor
Sound level	<70 dB(A)
Material conditions	
Material input pressure	3–30 bar
Material output pressure at 5 bar operating pressure	approx. 40 bar
Dosing speed	max. 250 ms/dosing cycle
Dosing quantity	0.02–2.5 cm ³
Connection input medium	M16x1.5 external thread
Connection output medium	G 1/4" external thread dosing valve. With standard adapter L600172: G 1/4" external thread > G 1/8" female thread
Permissible medium	NLGI class 0–3 (greases, oils, pastes, silicones)



DOSING VALVE DV25 ACCESSORIES



STROKE MONITORING P

DP-D-010-000020

Cylinder switch with reed contact for sensing the dosing and loading position.



STROKE MONITORING K

DP-D-010-000043

Switch with inductive sensor BES00HF for sensing the dosing and loading position.



SEALING PACKAGE

DP-D-010-000041

Complete package incl. sleeve with seal set and dosing needle.



HANDLE

DP-K-002-000020 // pneumatic

DP-K-002-000021 // electric

Handle for dosing valves for manual application.
Available in electric and pneumatic versions.

PLASTIC HOSE

DP-D-002-000030 // Outer diameter 2.5 mm

DP-D-002-000031 // Outer diameter 4 mm

Pressure-resistant plastic hose for dosing valves.
Connection 1: 1/8"
Connection 2: 1/8" or M6x0,57 (e.g. for dosing head)
Length approx. 0.2 m.



PROPORTIONAL DOSING VALVE PDV03

DP-D-005-000003



APPLICATION

With the PDV03 proportional dosing valve, continuous as well as spot application of oils and greases up to a volume of 0.5 cm³ is possible.

DESCRIPTION

The PDV03 proportional dosing valve is a split system and has no integrated electronics. The resulting more compact size allows it to be mounted directly at the point of use. In addition, the PDV03 operates electromechanically and does not require a pneumatic connection. The separate electronic control can be mounted flexibly with a permissible cable length of 3–20 meters. The control takes place via the D+P dosing system DS.

ADVANTAGES

The freely selectable metering volume can be infinitely adjusted and applied at variable speed with pinpoint accuracy or over a wide area. In the case of automated dispensing of several different positions on a workpiece, each position can be dispensed individually. This means that entire wetting profiles can be processed within one dispensing process. The PDV03 is viscosity-, pressure- and temperature-independent and ensures extremely process-reliable metering thanks to electronic monitoring of the valve piston by means of an encoder.

TECHNICAL DATA	
Mechanical data	
Weight	2 kg
Width x height x depth	85 x 59.5 x 335 mm
Max. pumpable viscosity	oils and greases up to NLGI class 3
Dosing quantity	0.01–0.5 cm ³
Medium inlet pressure	5–30 bar depending on application
Compressed air	4–6 bar
Compressed air quality	dried, filtered, oil-free
Electrical data	
Supply voltage	24 V DC
Fuse protection of the supply line	10 A
Max. power consumption	100 W
Quantity	1 inlet / 5 outlets
Type	outlets open collector with pull-up resistor to 24 V DC
Load	input 24 V DC/100 mA; outlets max. 10 mA to GND
Usage	inlets: switching of the control valve; outlets: motorready, motoractive, overtemperature
Supply voltage +24 V DC	min. –10 %, max. +10 %
Current consumption supply voltage +24 V DC	during dosing typically 3 A; at standstill 2 A; peak current 4 A
EMC resistance	according to EN 61000-6-2:2001 (industrial area)
Connection technology	17W2 Sub-D connector (supply, digital I/O) with mixed contacts; 9-pin Sub-D connector (RS485); external thread M16x1.5 nipple material inlet; Male thread G1/4" nipple material outlet
Environmental conditions	
Storage temperature	10–50 °C
Operating temperature	15–40 °C
Humidity	50–70 %, no condensation
Operation in closed rooms. Protect from direct sunlight, dust and moisture. Installation altitude, maximum 2000 meters above sea level.	



PROPORTIONAL DOSING VALVE PDV03 ACCESSORIES



CONTROL AND CONNECTION CABLE FOR PDV03

DP-D-005-000011	DP-D-005-000040
DP-D-005-000015	DP-D-005-000041
DP-D-005-000016	DP-D-005-000042

The control and connection cable is used for signal exchange between the dosing system and the PDV03 proportional dosing valve. The standard length is 5 meters, but can also be customized on request (max. 20 meters).

TECHNICAL DATA

Type	Cable length	Suitable for drag chain
DP-D-005-000011	5 m (standard)	no
DP-D-005-000015	7 m	no
DP-D-005-000016	10 m	no
DP-D-005-000040	5 m (standard)	yes
DP-D-005-000041	7 m	yes
DP-D-005-000042	10 m	yes



PRESSURE RELIEF VALVE UDV01 FOR PDV03

DP-D-005-000004

The pressure relief valve is an electrically interrogated safety element that switches off purely mechanically in the event of an improper increase in inlet pressure above 40 bar. It thus prevents both damage to the downstream components and the uncontrolled escape of the medium.

TECHNICAL DATA

Pressure range	15–40 bar
Connection	G 1/8"
Proximity switch	BES Q 05 AC-POC 15B-EP02
Dimensions	Ø 20 x 85 mm
Pressure stable	up to 300 bar

SEALING PACKAGE

DP-D-010-000019

Complete package incl. sleeve with seal set and dosing needle.



PROPORTIONAL DOSING VALVE PDV04

DP-D-005-000005



APPLICATION

The PDV04 enables uninterrupted dosing with freely selectable volumes from a quantity of 0.04 cm³ using the dosing principle with endless pistons.

DESCRIPTION

The PDV04 proportional dosing valve is an endless dosing valve and consists of an electrically driven piston metering unit.

The parameterization and control of the PDV04 is carried out via the control of the DS dosing system and thus enables continuous or clocked dosing. The standard interface to higher-level controls, e.g. for start or stop, is via digital I/Os. Further interfaces such as Profibus or Profinet are possible.

The compact and space-saving PDV04 proportional dosing system is designed for stationary as well as mobile use, e.g. on robots, and is connected to the D+P DS dosing system via a cable set of up to 20 meters in length.

ADVANTAGES

The PDV04 is viscosity-, pressure- and temperature-independent and ensures extremely process-safe metering thanks to electronic monitoring of the valve piston by means of an encoder.

In addition, the PDV04 operates electromechanically and does not require a pneumatic connection.

The maintenance-friendly arrangement of the seal packs has also been implemented for the PDV04 in accordance with our new dosing valve series.

TECHNICAL DATA	
Weight	3.8 kg 4.0 kg with spray attachment
Width x height x depth	137 x 210.1 x 110 mm 137 x 226.1 x 127.1 mm with spray attachment
Dosing data	
Max. pumpable viscosity	Oils and greases NLGI class 0–3
Dosing quantity	from 0.04 cm ³
Tolerance (depending on application and medium)	>1 g ± ~1 % <1 g ± ~7 %
Volume flow	0.007–3.2 cm ³ /s
Inlet pressure	5–30 bar
Connection technology	
Hydraulic	G 1/4" material inlet external thread G 1/4" material outlet external thread
Electric	motor connection: M12 plug 5pin encoder connection: M12 plug 8pin / 5 V DC - 3 V; 424 A
Motor heating	max. 80 °C
Environmental conditions	
Air temperature operation	10–50 °C
Air temperature transport and storage	0–50 °C
Humidity	50– max. 70 %, no condensation
Protection class	IP54
Operation in closed rooms. Protect from direct sunlight, dust and moisture. Installation altitude, max. 2000 meters above sea level.	



PROPORTIONAL DOSING VALVE PDV04 ACCESSORIES



SPRAY ATTACHMENT FOR PDV04 WITH ACCESSORIES

DP-D-005-000050

APPLICATION

The spray attachment is mounted directly on the PDV04 and enables contactless, homogeneous and repeatable application of media with low to high viscosity.

DESCRIPTION

Volumetric dosing ensures reliable quantity application, regardless of the viscosity of the dosing medium.

The web speed-controlled application, simple dosing quantity adjustment and the optional control of pre- and post-air offer maximum control over the application. The attachment is compatible with all standard nozzles, air caps and nozzle extensions of our spray valves.

The set consists of

- ▶ Spray attachment PDV04 DP-D-005-000051
- ▶ Atomizing air pressure control DP-D-005-000052
- ▶ Atomizing air solenoid valve DP-D-005-000053

ADVANTAGES

- ▶ Contactless, precise dosing for media with variable viscosity
- ▶ Reliable quantity application regardless of the viscosity of the dosing medium
- ▶ Simple adjustment of the dosing quantities via the control unit
- ▶ Path speed-controlled application for flexible use
- ▶ Compatibility with standard nozzles, air caps and nozzle extensions
- ▶ Versatile use for a wide range of applications



PDV04 with mounted spray attachment

TECHNICAL DATA

Weight	0.2 kg
Width x height x depth	84 x 56.5 x 48 mm
Connection atomizing air	0–6 bar (precision pressure regulator)
Material outlet	nozzles 0.3–2.5 mm
Connection material outlet	M21 x 0.75



PROPORTIONAL DOSING VALVE PDV04 ACCESSORIES



CONTROL AND CONNECTION CABLE FOR PDV04

DP-D-005-000012
DP-D-005-000017
DP-D-005-000018

The control and connection cable is used for signal exchange between the dosing system and the PDV04 proportional dosing valve. The standard length is 5 meters, but can also be customized on request (max. 20 meters).

TECHNICAL DATA

Type	Cable length	Suitable for drag chain
DP-D-005-000012	5 m (standard)	yes
DP-D-005-000017	7 m	yes
DP-D-005-000018	10 m	yes

SEALING PACKAGE

DP-D-010-000013

Complete package incl. sleeve with seal set and dosing needle.

OUTLET CHECK VALVE (SPARE PART)

DP-D-011-000006

Spare part for PDV04. The outlet check valve prevents the medium from flowing back into the dosing system and thus ensures the one-way direction of the flow.



DOSING VALVE STATION

DP-K-005-000005 // 41965.00
 DP-K-005-000006 // 41970.00
 DP-K-005-000007 // 41975.00



The dosing valve station offers a simple and quick mounting option directly on the valve. A 5/2-way valve is to be provided for control. The dosing valve station is available in different metering quantity ranges.

The repeat accuracy in the medium metering range is +/-2 %. The desired metering quantity is infinitely adjustable with a regulating sleeve. Application nozzles are customized and screwed directly to the dosing valve.

TECHNICAL DATA

Type	41965.00	41970.00	41975.00
Dosing quantity	2.0–26 cm ³	5.0–54 cm ³	10–133 cm ³
Material input pressure	max. 200 bar	max. 200 bar	max. 200 bar
Material output pressure	80 bar	80 bar	80 bar
Connection thread	G 1/4"	G 1/4"	G 1/4"
Permissible material	oils and greases NLGI class 0–3	oils and greases NLGI class 0–3	oils and greases NLGI class 0–3
With back suction	X	X	X



MINI DOSING VALVE

DP-K-002-000040 // Dosing valve C-419.01.00
DP-K-002-000051 // Dosing valve C-450.20.00
DP-K-002-000060 // Dosing valve C-450.20.03



APPLICATION

The mini dosing valve enables spot application of low to high viscosity media in very small quantities.

DESCRIPTION

The valve consists of two structurally separate parts. This design prevents uncontrolled leakage of the medium into the pneumatic cylinder and thus prevents interference with the valve needle.

The shot volume can be set within a predefined range using the stop screw.

The dispensing cycle is controlled pneumatically or electrically by means of a solenoid valve.

Manual application by hand is just as possible as integration into a fully automated process.

Included is a cannula that is customized.

ADVANTAGES

The mini dosing valve is characterized by high reproducibility, short cycle times and low maintenance requirements.

TECHNICAL DATA

Type	C-419.01.00	C-450.20.00	C-450.20.03
Dosing quantity	0.05–1.0 cm ³	0.003–0.200 cm ³	0.003–0.200 cm ³
Min. material pressure	3 bar	3 bar	3 bar
Max. material pressure	75 bar	20 bar	50 bar
Material connection	cannula connection	G 1/4"	G 1/4"
Length x width x height	40 x 40 x 299 mm	35 x 35 x 260 mm	35 x 35 x 260 mm
Weight	1480 g	750 g	750 g



MINI DOSING VALVE ACCESSORIES



HANDLE

DP-K-002-000020 // pneumatic
DP-K-002-000021 // electric

Handle for dosing valves for manual application.
Available in electric and pneumatic versions.

STROKE MONITORING FOR MINI DOSING VALVE WITH INITIATOR

DP-K-002-000025

STROKE MONITORING 2-FOLD FOR MINI DOSING VALVE WITH INITIATOR

DP-K-002-000027



CHAMBER DOSING VALVE

DP-K-002-000065 // Dosing valve 1029662
DP-K-002-000066 // Dosing valve 1023208

DP-K-002-000008 // Dosing valve C-415.12.00
DP-K-002-000009 // Dosing valve C-415.12.21



APPLICATION

The chamber dosing valve enables dot application of low to high viscosity media. In contrast to the mini dosing valve, it covers a wider range of possible dosing quantities.

DESCRIPTION

The valve consists of two structurally separate parts. This design prevents uncontrolled leakage of the medium into the pneumatic cylinder and thus prevents interference with the valve needle.

The shot volume can be set within a predefined range using the stop screw. The dispensing cycle is controlled pneumatically or electrically by means of a solenoid valve.

Manual application by hand is just as possible as integration into a fully automated process.

ADVANTAGES

The chamber dosing valve is characterized by high reproducibility, short cycle times and low maintenance requirements.

The mode of operation also enables higher process reliability as well as a suck-back effect, which prevents dripping of low-viscosity media.

TECHNICAL DATA

Type	1029662	1023208	C-415.12.00	C-415.12.21
Dosing quantity	0.05–0.5 cm ³	0.1–3 cm ³	0.5–12 cm ³	0.5–12 cm ³
Min. material pressure	40 bar	40 bar	40 bar	40 bar
Max. material pressure	80 bar	80 bar	80 bar	80 bar
Material connection	G 1/8"	G 1/8"	G 1/4"	G 1/4"
Pneumatic connection	G 1/8"	G 1/8"	2 x G 1/8"	2 x G 1/8"
Length x width x height	68 x 30 x 151 mm	68 x 30 x 194 mm	107 x 40 x 171 mm	107 x 40 x 171 mm
Weight	600 g	730 g	1960 g	1960 g



CHAMBER DOSING VALVE ACCESSORIES



HANDLE

DP-K-002-000020 // pneumatic
DP-K-002-000021 // electric

Handle for dosing valves for manual application.
Available in electric and pneumatic versions.

STROKE MONITORING 2-FOLD FOR DOSING VALVE

DP-K-002-000034

STROKE MONITORING 2-FOLD FOR C-SLOT ON DOSING VALVE

DP-K-002-000041

STROKE MONITORING 2-FOLD FOR DOSING VALVE (NEW VALVE GENERATION)

DP-K-002-000042



GREASE SHOT VALVE FSV02 SINGLE

DP-D-007-000005



APPLICATION

The grease shot valve is used to apply various viscous media from a distance of up to 120 mm.

DESCRIPTION

The FSV02 simple includes a solenoid valve, as well as a micromodule with optimized nozzle and heating with two heating controllers. The material is discharged with perfect tear-off as a point or bead.

The control takes place exclusively via the D+P dosing system.

Available nozzle sizes: Ø 0.21–0.81 mm

ADVANTAGES

The 2-valve shut-off technology enables metering of very small quantities with very short switching times, and the compact design means that the nozzle can be optimally used even in the tightest of spaces.

The valve is splash-proof and has an integrated material filter to ensure permanently clean material discharge.

TECHNICAL DATA

Mechanical data	
Width	348 mm
Height	625 mm
Depth	273 mm
Mounting position	any, even overhead
Max. pumpable viscosity	oils and greases NLGI class 0–3
Application quantity per shot	1–20 cm ³
Material temperature	max. 120 °C
Switching frequency	max. 100 Hz
Medium inlet pressure	5–68 bar, depending on application – depending on viscosity
Order distance	max. 120 mm
Heating time	approx. 5 min
Pneumatic air pressure	6 bar, optionally with pressure booster combination
Line length control air	max. 100 mm
Environmental conditions	
Storage and transport temperature	–40–70 °C
Working temperature	35–65 °C
Ambient temperature	–7–50 °C
Humidity	50–70 %
Material	For all work, the material must be brought to the correct processing temperature. Note this temperature when: <ul style="list-style-type: none">▶ the material comes from cold storage rooms,▶ a heater is provided for heating the material,▶ cooling is provided for cooling the material.
Other	Operation in closed rooms. Protect from direct sunlight, dust and moisture. Installation altitude maximum 2000 meters above sea level.
EMC resistance	according to EN 61000-6-2:2001 (industrial area)
Electrical data	
Temperature sensor	PT 100 / 2 conductors
Power supply	240 V AC 50–60 Hz
Power heating	240 V: 155 W



GREASE SHOT VALVE FSV02 ACCESSORIES



FIBER OPTIC LIGHT BARRIER FOR FSV02

DP-D-007-000003

For monitoring in the millisecond range during grease application. The photoelectric sensor detects and transmits the number of shots to the DS02 dispensing system.



VCA HOLDER FOR FSV02

DP-D-007-000007

Holder for direct attachment of the VCA volume sensor to the FSV02 Grease shot valve.



COLLECTION TRAY FOR FSV02

DP-D-007-000008

Grease collection tray for medium.

BLOW CLEAR DEVICE FOR FSV02

DP-D-007-000004

Cleans the grease nozzle with bursts of compressed air at adjustable intervals and prevents grease build-up on the nozzle.

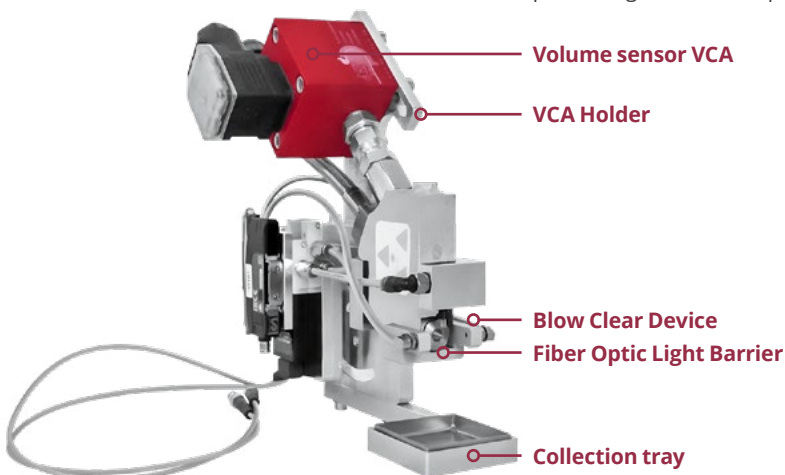



PRESSURE BOOSTER

DP-K-012-000010 // 2 liters compressed air reservoir

DP-K-012-000011 // 5 liters compressed air reservoir



2 liters compressed air reservoir



3 liters compressed air reservoir

Pneumatic pressure booster used for targeted increase of operating pressure. The desired output pressure can be set manually on the pressure regulator. The pressure booster compensates for pressure fluctuations between the inlet and outlet pressure.

TECHNICAL DATA

Type	2 liters compressed air reservoir	5 liters compressed air reservoir
Constructive structure	double piston pressure intensifier with air reservoir and check valve	double piston pressure intensifier with air reservoir and check valve
Pressure display	with pressure gauge	with pressure gauge
Outlet pressure	4.5–10 bar	4.5–10 bar
Operating pressure	2.5–8 bar	2.5–8 bar
Pressure control range	4.5–10 bar	4.5–10 bar
Inlet pressure	2–8 bar	2–8 bar
Weight	4400 g	7300 g



SPRAYING VALVE SVEP

DP-K-003-000010 // SVEP-FK-RN-00-KLS05-F60-00
 DP-K-003-000011 // SVEP-FK-RN-00-KLS05-R15-00
 DP-K-003-000012 // SVEP-FK-RN-00-00000-000-00



APPLICATION

The SVEP spraying valve is used for the application of release agents, oils and paints and is suitable for both pulsating and continuous application.

DESCRIPTION

The special feature of the SVEP series is the integrated spray air valve, which can be used to set the postblow duration for nozzle cleaning. Optionally with needle sensing.

Available nozzle sizes: Ø 0.2 / 0.3 / 0.5 / 0.8 / 1.0 / 1.2 / 1.5 / 2.0 / 2.5 mm

ADVANTAGES

Short air paths in the body as well as the directly flanged 5/2 way solenoid valve allow very fast and precise pulsations. The raster regulation allows easy adjustment of the material quantity.

The spray pattern can be individually adapted via different air cap and nozzle variants.

VARIANTS

- ▶ **SVEP-FK-RN-00-KLS05-F60-00**
Spraying valve with flat jet attachment with integrated spray control
- ▶ **SVEP-FK-RN-00-KLS05-R15-00**
Spraying valve with round jet attachment with integrated spray control
- ▶ **SVEP-FK-RN-00-00000-000-00**
with integr. spray air control o. nozzle, o. air cap

TECHNICAL DATA	
Material pressure	max. 35 bar
Control air pressure	min. 5–6 bar
Length x width x height	132 x 81 x 22 mm (incl. solenoid valve)
Main body	stainless steel
Nozzle + needle	stainless steel
Seals	Viton (other materials on request)



SPRAYING VALVE SVSV

DP-K-003-000015



APPLICATION

The SVSV spraying valve is used for the application of release agents, oils and paints and is suitable for both pulsating and continuous application.

DESCRIPTION

The SVSV is a pneumatically actuated spraying valve. It is controlled by external solenoid valves or mechanical valves.

Remote adjustment is possible by using a second air connection (option).

Available nozzle sizes: Ø 0.2 / 0.3 / 0.5 / 0.8 / 1.0 / 1.2 / 1.5 / 2.0 / 2.5 mm

ADVANTAGES

The spray air volume for the horn air can be adjusted separately, this allows the spray pattern to be adapted to individual requirements at any time – from round jet to 90° flat jet. The raster regulation allows easy adjustment of the material quantity. In the event of a defect in the needle seal, the material does not run into the air duct but out of the unit, thus preventing contamination of the air duct.

TECHNICAL DATA

Injection material pressure	max. 10 bar
Control air pressure	3.5–6 bar
Spray air pressure	should be adapted to the pressure of the sprayed material
Length x width x height	50 x 45 x 72.5 mm
Main body	stainless steel
Nozzle + needle	stainless steel
Weight	approx. 305 g



SPRAYING VALVE SVKA

DP-K-003-000016 // SVKA-FK-RN-S-KLS05-F60-00
 DP-K-003-000017 // SVKA-FK-RN-S-KLS05-R15-00
 DP-K-003-000018 // SVKA-FK-RN-S-00000-000-00



APPLICATION

The SVKA spraying valve is suitable for spraying thin-bodied media, e.g. release agents, oils or paints.

DESCRIPTION

Depending on the air cap used, a flat or a round jet can be generated. Depending on the viscosity of the medium to be applied, the application pattern can be individually adjusted via the nozzle size and the spray air pressure.

The connections of the three function hoses (control air, atomization air and material hose) can be optionally mounted on the side or on the rear.

Optional with mounting bracket (Ø 10 mm).

Available nozzle sizes: Ø 0.2 / 0.3 / 0.5 / 0.8 / 1.0 / 1.2 / 1.5 / 2.0 / 2.5 mm

ADVANTAGES

The SVKA's light weight and compact size make it ideal for all spraying applications where there is very little space available for installation in machines or robots.

The raster regulation allows easy adjustment of the material quantity.

The spray pattern can be individually adapted via different air cap and nozzle variants.

VARIANTS

- ▶ **SVKA-FK-RN-S-KLS05-F60-00**
Spraying valve with flat jet 60°
- ▶ **SVKA-FK-RN-S-KLS05-R15-00**
Spraying valve with round jet 15°
- ▶ **SVKA-FK-RN-S-00000-000-00**
without nozzle

TECHNICAL DATA	
Injection material pressure	max. 3 bar
Control air pressure	3–6 bar
Spray air pressure	0.5–6 bar
Length x width x height	42 x 25 x 25 mm with flat jet cap
Length x width x height	39 x 25 x 25 mm with round jet cap
Main body	stainless steel
Nozzle + needle	stainless steel
Seals	Viton (other materials on request)



EXTRUSION VALVE EV40

DP-K-003-000027



APPLICATION

Depending on the nozzle size, the extrusion valve is used for the non-contact application of media with different viscosities, such as sealants, adhesives, greases and oils, and is suitable for both pulsating and continuous application.

DESCRIPTION

The EV40 extrusion valve is an electro-pneumatically controlled applicator. The spraying process is generated by the control air and the material feed pressure and can be carried out either as an intermittent or continuous process.

It is controlled via the 5/2-way solenoid valve integrated in the body.

The valve is available with both a short nozzle (KV) and a long nozzle (LV).

Optionally with raster regulation including needle monitoring (function monitoring of the needle).

ADVANTAGES

Short paths within the entire air supply range and the fast-switching solenoid valve allow up to 20 switching cycles per second.

The grid regulation enables the material quantity to be set easily.

TECHNICAL DATA	
Weight	approx. 400 g
Length x width x height	143 x 58 x 15 mm (LV nozzle); 125 x 58 x 15 mm (KV nozzle)
Material pressure	max. 100 bar with control air (closing air); max. 30 bar without control air (closing air)
Control air pressure	min. 6 bar
Intermittents	up to 20 cycles per second
Main body	stainless steel or brass, chemically nickel-plated
Nozzle	stainless steel
Needle	hard metal
Seals	Viton (other materials on request)



EXTRUSION VALVE EV50

DP-K-003-000019



APPLICATION

Depending on the nozzle size, the extrusion valve is used for the non-contact application of media with different viscosities, such as sealants, adhesives, greases and oils, and is suitable for both pulsating and continuous application.

DESCRIPTION

The EV50 extrusion valve is an electro-pneumatically controlled applicator. The spraying process is generated by the control air and the material feed pressure and can be carried out either as an intermittent or continuous process.

It is controlled via the 5/2-way solenoid valve integrated in the body.

The valve is available with both a short nozzle (KV) and a long nozzle (LV).

Optionally with raster regulation including needle monitoring (function monitoring of the needle).

ADVANTAGES

Short paths within the entire air supply range and the fast-switching solenoid valve allow up to 200 switching cycles per second.

The grid regulation enables the material quantity to be set easily.

TECHNICAL DATA	
Weight	approx. 400 g
Length x width x height	143 x 58 x 15 mm (LV nozzle); 125 x 58 x 15 mm (KV nozzle)
Material pressure	max. 100 bar with control air (closing air); max. 30 bar without control air (closing air)
Control air pressure	min. 6 bar
Intermittents	up to 200 cycles per second
Main body	stainless steel or brass, chemically nickel-plated
Nozzle	stainless steel
Needle	hard metal
Seals	Viton (other materials on request)



SPRAYING/EXTRUSION VALVES ACCESSORIES



PRECISION PRESSURE REGULATOR LRP-1/4-4 WITH PRESSURE GAUGE

DP-K-002-000070

The precision pressure control valve is used for fine adjustment of the pneumatic inlet pressure for the spray air at the spraying valve. With it, the spraying behavior can be optimally adapted to the individual framework conditions, such as the applied medium, distance and environment.

TECHNICAL DATA

Connection thread	G 1/4"
Flow rate	2000 l/min
Pressure control range	0.05–4 bar
Length x width x height	143 x 58 x 15 mm
Incl. mounting bracket HR-1/4-P	

SEALING SCREW

DP-K-003-000105

Sealing screw incl. all seals between needle and nozzle.

▶ ▶ ▶ SVEP, SVPP, EV40, EV50

SEALING BUSH

DP-K-003-000109

Sealing bush incl. all seals between needle and nozzle.

▶ ▶ ▶ SVEP, SVPP, EV40, EV50

PRESSURE TRANSMITTER 1/8"

DP-K-003-000116

Pressure transmitter 0–50 bar for monitoring the process-relevant medium pressure.

▶ ▶ ▶ SVEP, EV40, EV50



SPRAYING/EXTRUSION VALVES ACCESSORIES

MAGNETIC VALVE

DP-K-003-000102 // for SVEP
DP-K-003-000113 // for EV40
DP-K-003-000115 // for EV50

Solenoid valve 5/2 ways for 24 V, incl. plug.

▶ ▶ ▶ SVEP, EV40, EV50

RASTER NEEDLE LOCK SPRAYING VALVES

DP-K-003-000100 // for SVEP
DP-K-003-000101 // for SVEP, with sensing
DP-K-003-000106 // for SVPP
DP-K-003-000107 // for SVPP, with sensing

Lock for easy adjustment of the needle stroke.

▶ ▶ ▶ SVEP, SVPP

RASTER NEEDLE SENSING

DP-K-003-000108 // for SVSV, complete
DP-K-003-000110 // for SVKA/SVKAHD, complete

▶ ▶ ▶ SVSV, SVKA, SVKAHD

VALVE HEATING

DP-K-003-000091 // for SVPP/SVEP
DP-K-003-000094 // for EV50

Heater for mounting on automatic valves.
Incl. pre-assembled cable with plug, heating element and temperature sensor.

▶ ▶ ▶ SVPP, SVEP, EV50

HEATING HOSE DKR 3/8"

DP-K-003-000092 // L = 1 meter



SPRAYING/EXTRUSION VALVES ACCESSORIES

MATERIAL SEAL SET

DP-K-003-000104 // for SVEP/SVPP/EV40/EV50

All seals that come into contact with the medium.

▶▶▶ SVEP, SVPP, EV40, EV50

INSULATING PLATE

DP-K-003-000090 // for SVPP/SVEP

DP-K-003-000093 // for EV50

▶▶▶ SVEP, SVPP

AIR VALVE

DP-K-003-000103 // for SVEP, complete

▶▶▶ SVEP



NOZZLE EXTENSIONS

The D8 series extensions have been specially developed for applications where only very limited space is available for installation in machines or robots. The needle seals in the extension tip. This means that no dripping is possible.
Scope of delivery: complete nozzle extension

EXTENSION, STRAIGHT (ROUND JET) SPRAYING

Brass // DP-K-003-000030
Stainless steel // DP-K-003-000050

EXTENSION, STRAIGHT (FLAT JET) SPRAYING

Brass // DP-K-003-000031

EXTENSION, 45° ANGLED SPRAYING, SPRAYING PATTERN OVAL OR ROUND

Brass // DP-K-003-000032

EXTENSION, 45° UNICORN ANGLED, SPRAYING

Stainless steel // DP-K-003-000052

EXTENSION, 90° ANGLED SPRAYING, SPRAYING PATTERN OVAL OR ROUND

Brass // DP-K-003-000033
Stainless steel // DP-K-003-000051

EXTENSION, 90° UNICORN ANGLED, SPRAYING

Stainless steel // DP-K-003-000053

EXTENSION, RING JET SPRAYING 360°, IDEALLY SUITED FOR INTERNAL SPRAYING OF CYLINDRICAL HOLLOW BODIES

Brass // DP-K-003-000034
Stainless steel // DP-K-003-000054

The nozzle extensions can be supplied in any desired length.
D6 series extension = outer Ø 6 mm also possible on request.



OUTLET VALVE AV25

DP-D-010-000042



APPLICATION

The AV25 outlet valve is suitable for applying low to high viscosity media.

DESCRIPTION

The valve consists of two structurally separate parts. This design prevents uncontrolled leakage of the medium into the pneumatic cylinder and thus prevents interference with the valve needle.

The size of the opening cross-section is regulated by the stroke adjustment of the valve needle. Sealing of the valve needle against the valve head space is provided by the nozzle seat set.

ADVANTAGES

- ▶ Small material rooms
- ▶ High opening and closing force
- ▶ Pneumatic double control
- ▶ Easily replaceable seal package as well as nozzle seat set
- ▶ Exchangeable pneumatic cylinder

TECHNICAL DATA

Length x width x height	150 x 41 x 41 mm
Weight	650 g
Pneumatic operating pressure	
Pressure	4.5–10 bar
Quality compressed air	dried, filtered, oil-free
Pneumatic connections	M5 female thread
Product features	
Clear width LW	2.5
Material input pressure	0.5–30 bar
Material outlet pressure	0.5–30 bar
Material connection input/output	G 1/8" female thread
Permissible media	oils and greases NLGI class 0–3



ACCESSORIES OUTLET VALVE AV25



STROKE MONITORING P

DP-D-010-000020

Cylinder switch with reed contact for sensing the dosing and loading position.



STROKE MONITORING K

DP-D-010-000043

Switch with inductive sensor BES00HF for sensing the dosing and loading position.



NOZZLE SEAT SET

DP-D-010-000044

Complete package incl. sleeve with seal set and dosing needle.



HANDLE

DP-K-002-000020 // pneumatic

DP-K-002-000021 // electric

Handle for dosing valves for manual application.
Available in electric and pneumatic versions.

PLASTIC HOSE

DP-D-002-000030 // Outer diameter 2.5 mm

DP-D-002-000031 // Outer diameter 4 mm

Pressure-resistant plastic hose for dosing valves.
Connection 1: 1/8"
Connection 2: 1/8" or M6x0,57 (e.g. for dosing head)
Length approx. 0.2 m.



MANUAL OUTLET VALVE HAV25

DP-D-010-000046



APPLICATION

The HAV25 manual outlet valve is suitable for manual application of low to high viscosity media.

DESCRIPTION

The HAV25 manual outlet valve is based on our well-established AV25 outlet valve. The pneumatic part of the dosing valve is controlled by a pneumatic 5/2-way valve. Dosing is started by actuating the trigger. The dosing speed depends on the material pressure (medium).

The design consisting of two separate parts prevents uncontrolled leakage of the medium into the pneumatic cylinder and thus prevents interference with the valve needle.

The size of the opening cross-section is regulated by the stroke adjustment of the valve needle. Sealing of the valve needle against the valve head space is provided by the nozzle seat set.

The user-friendly design and the non-slip gripping surface enable uncomplicated and quick handling and are ideal for use with balancer.

ADVANTAGES

- ▶ Small material spaces
- ▶ High opening and closing force
- ▶ Pneumatic double control
- ▶ Easily replaceable seal package and nozzle seat set
- ▶ Interchangeable pneumatic cylinder

TECHNICAL DATA

Length x width x height	181 x 54 x 79 mm
Weight	1.06 kg
Pneumatic operating pressure	
Pressure	4.5–10 bar
Quality compressed air	dried, filtered, oil-free
Pneumatic connections	M5 female thread
Product features	
Clear width LW	2.5
Material input pressure	0.5–30 bar
Material outlet pressure	0.5–30 bar
Material connection input/output	G 1/8" female thread
Permissible media	oils and greases NLGI class 0–3



ACCESSORIES MANUAL OUTLET VALVE HAV25



STROKE MONITORING P

DP-D-010-000020

Cylinder switch with reed contact for sensing the dosing and loading position.



NOZZLE SEAT SET

DP-D-010-000044

Complete package incl. sleeve with seal set and dosing needle.

PLASTIC HOSE

DP-D-002-000030 // Outer diameter 2.5 mm

DP-D-002-000031 // Outer diameter 4 mm

Pressure-resistant plastic hose for dosing valves.

Connection 1: 1/8"

Connection 2: 1/8" or M6x0,57 (e.g. for dosing head)

Length approx. 0.2 m.



OUTLET VALVE

DP-K-002-000032 // Dosing valve C-401.09.01
DP-K-002-000035 // Dosing valve C-401.09.02
DP-K-002-000054 // Dosing valve C-401.00.24



APPLICATION

The outlet valve is suitable for continuous discharge of low to high viscosity media.

DESCRIPTION

The valve consists of two structurally separate parts. This design prevents uncontrolled leakage of the medium into the pneumatic cylinder and thus prevents interference with the valve needle.

The size of the opening cross-section is regulated by the stroke adjustment of the valve needle. The valve needle is sealed against the valve head chamber by a special adjustable seal.

ADVANTAGES

- ▶ Small material rooms
- ▶ High opening and closing force
- ▶ Adjustable special seals
- ▶ Pneumatic double control
- ▶ High max. working pressures

TECHNICAL DATA

Type	C-401.09.01	C-401.09.02	C-401.00.24
Length x width x height	35 x 35 x 260 mm	35 x 35 x 240 mm	20 x 23 x 130 mm
Weight	520 g	400 g	200 g
Pneumatic connection	2 x i G 1/8"	2 x i G 1/8"	2 x i M5
Clear width LW	2,5	2,0	1,0
Operating pressure	250 bar	250 bar	250 bar
Max. material pressure	315 bar	315 bar	315 bar
Material connection	cannula connection	cannula connection	cannula connection
Permissible media	oils and greases NLGI class 0-3	oils and greases NLGI class 0-3	oils and greases NLGI class 0-3



ROTARY GREASING UNIT RBE02

DP-D-006-000001 // rotary head 150 mm
 DP-D-006-000003 // rotary head 70 mm
 DP-D-006-000007 // rotary head 260 mm



Optionally available with
rotation control



APPLICATION

The RBE02 rotary greasing unit is designed for non-contact wetting of internal contours.

DESCRIPTION

The RBE02 rotary greasing unit is a rotary head with electric drive and optional rotary control. The material is applied without air by centrifugal force. The continuous supply of lubricant ensures uniform greasing of the workpiece.

ADVANTAGES

- ▶ High flexibility, material application for a wide range of component contours
- ▶ Airless material application by centrifugal force with various viscous media
- ▶ Very low grease carryover
- ▶ Minimum wetting diameter \varnothing from 36 mm (depending on the application)

TECHNICAL DATA

Mechanical data

Minimum wetting diameter	\varnothing 36 mm
Smallest rotor	\varnothing 14 mm
Largest rotor	\varnothing 20 mm
Rotor dimensions	Various rotor configurations available (We would be happy to determine the perfect configuration for your application in a metering test).
Length with standard rotor head 70 mm	280 mm
Length with standard rotor head 150 mm	350 mm
Length with standard rotor head 260 mm	455 mm
Height	60 mm
Width	60 mm
Permissible media	oils and greases NLGI class 0–3
Conveying capacity	max. 1 cm ³ /s
Weight	1.9 kg
Volume	< 70 db(A)

Motor data

U_N	24 V DC
I_N	4.8 A
P_2	89 W
n_N	max. 17.000 U/min
M_N	5 Ncm
Protection class	IP54

Environmental conditions

Operating temperature	10–40 °C
Humidity	40– max. 70 %



ROTARY GREASING UNIT RBE03

DP-D-006-000005

**APPLICATION**

The RBE03 rotary greasing unit is designed for non-contact wetting of internal contours.

DESCRIPTION

The RBE03 rotary greasing unit is a rotary head with electric drive and optional rotary control. The material is applied without air by centrifugal force. The continuous supply of lubricant ensures uniform greasing of the workpiece.

ADVANTAGES

- ▶ High flexibility, material application for a wide range of component contours
- ▶ Airless material application by centrifugal force with various viscous media
- ▶ Very low grease carryover
- ▶ Minimum wetting diameter \varnothing from 5 mm (depending on the application)

TECHNICAL DATA**Mechanical data**

Minimum wetting diameter	\varnothing 5 mm
Rotor dimensions	Various rotor configurations available. (We would be happy to determine the perfect configuration for your application in a dosing test.)
Length with standard rotor head 50 mm	214 mm
Rotor \varnothing	\varnothing 8 mm
Other lengths and diameters on request (depending on medium and general conditions)	
Height	86 mm
Depth	60 mm
Medium connection	1/8 "
Permissible media	oils and greases NLGI class 0-3
Conveying capacity	max. 1 cm ³ /s
Weight	1.15 kg
Volume	< 70 dB(A)

Motor data

U_N	24 V DC
I_N	4.6 A
P_2	89 W
n_N	max. 17.000 U/min
M_N	5 Ncm
Protection class	IP54

Environmental conditions

Operating temperature	10-40 °C
Humidity	40- max. 70 %



ROTARY GREASING UNIT RBE04

DP-D-006-000006 // rotary head 150 mm



APPLICATION

The RBE04 rotary greasing unit is designed for non-contact wetting of internal contours.

DESCRIPTION

The RBE04 rotary greasing unit is a rotary head with electric drive and optional rotary control. The material is applied without air by centrifugal force. The continuous supply of lubricant ensures uniform greasing of the workpiece.

ADVANTAGES

- ▶ High flexibility, material application for a wide range of component contours
- ▶ Airless material application by centrifugal force with various viscous media
- ▶ Very low grease carryover
- ▶ Minimum wetting diameter \varnothing from 20 mm (depending on the application)

TECHNICAL DATA

Mechanical data

Minimum wetting diameter	\varnothing 20 mm
Length with standard rotor head 70 mm	285 mm
Length with standard rotor head 150 mm	355 mm
Rotor \varnothing	\varnothing 10 mm
Other lengths and diameters on request (depending on medium and general conditions)	
Height	60 mm
Depth	60 mm
Medium connection	1/8 "
Permissible media	oils and greases NLGI class 0–3
Conveying capacity	max. 1 cm ³ /s
Weight	1.85 kg
Volume	< 70 dB(A)
Motor data	
U_N	24 V
I_N	4.8 A
P_2	89 W
n_N	max. 17.000 U/min
M_N	5 Ncm
Protection class	IP54
Environmental conditions	
Operating temperature	10–40 °C
Humidity	40– max. 70 %



ROTARY GREASING UNIT RBE ACCESSORIES



ROTARY CONTROL FOR RBE02 / 04

DP-D-006-000014

In order to be able to guarantee process-reliable greasing, it is possible to monitor the rotation. The monitoring is carried out optoelectronically.



VCA / VC ANGLE HOLDER

RBE02 // DP-D-006-000016 / DP-D-006-000022
RBE03 // DP-D-006-000021 / DP-D-006-000023

Angle holder to attach the VCA / VC flow meter directly to the rotary greasing unit.



ELECTRIC INFEEED AXIS TOOTHED BELT AXIS WITH ACCESSORIES

Horizontal // DP-D-005-000020
Vertical // DP-D-005-000024

Toothed belt infeed axis with brake (safe-stop), enables a safe stop when operating a light curtain or other safety component. Includes mounting plate and bracket for attaching the infeed unit to customer's rack (hole punching to be agreed upon). Available in horizontal or vertical version.

- ▶ Drive motor with gearbox and controller
 - ▶ Cabling, incl. wiring of the components
 - ▶ Plug-in connections
 - ▶ Standard stroke 200 mm
 - ▶ Other stroke sizes possible on request
-

UDS HOLDER FOR RBE03

DP-D-006-000024

Holder to attach the UDS ultrasonic flow sensor directly to the RBE03 rotor lubrication unit.

SEALING PACKAGE FOR RBE03

DP-D-006-000025

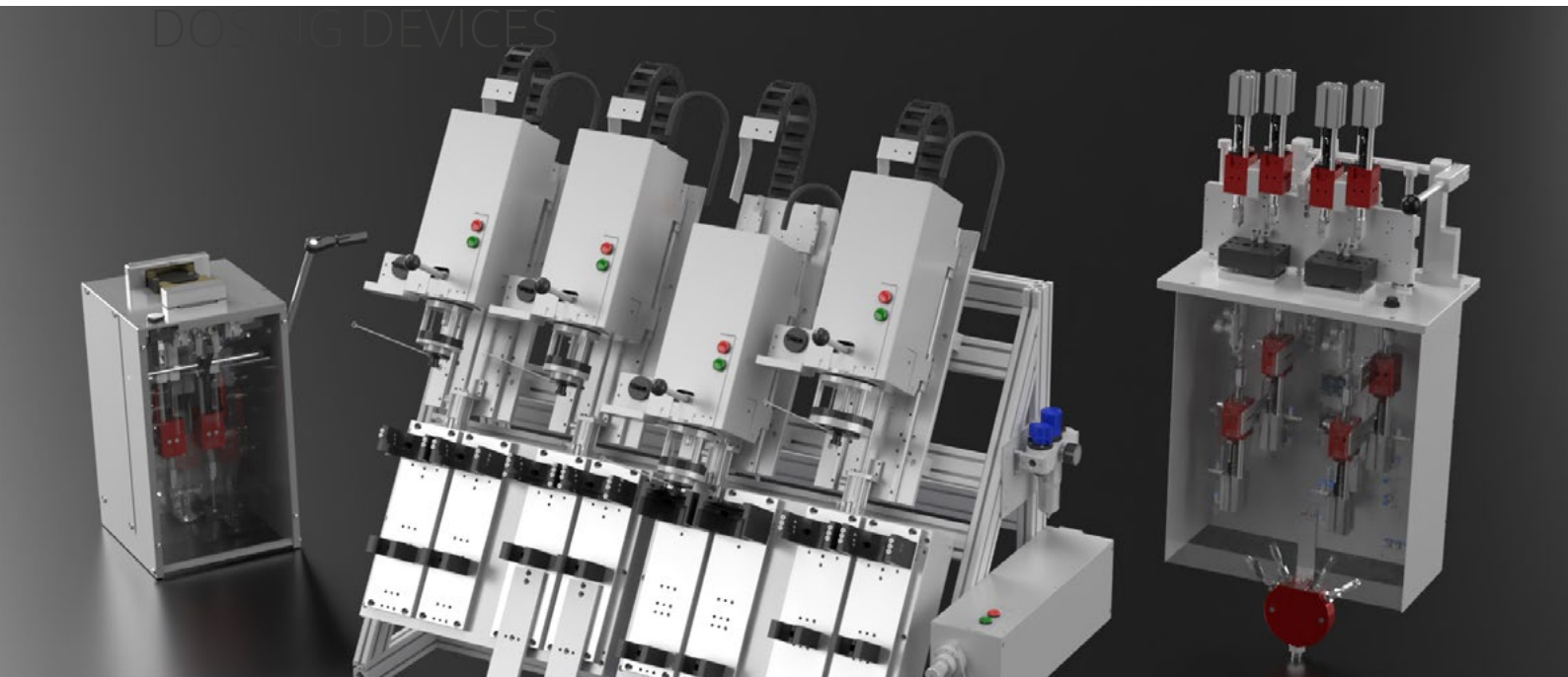

DEVICES

EFFICIENT MEDIA APPLICATION SYSTEMS

Accurate and precise application of media is essential for the manufacture of high-quality products. Incorrectly positioned or over-applied media can not only lead to immediate product defects, but can also drastically shorten the service life of products in live operation. To counteract these challenges, we offer advanced solutions.

VARIOUS APPLICATIONS

Our dosing devices have been specially developed to ensure precise dosing of viscous media. Regardless of the application - be it surface, contour or dot application - our systems offer you a wide range of options.

CUSTOMIZED SOLUTIONS

We understand that every customer has unique requirements. That's why we offer customized solutions that are tailored exactly to your needs. Our experts will work closely with you to develop a system that meets your production requirements. Whether it's specific media, component geometries or manufacturing processes, we customize our technology to ensure maximum efficiency and quality.

VERSATILE AREAS OF APPLICATION

- ▶ Our technology is suitable for a wide range of components and surfaces, such as
- ▶ O-rings
- ▶ Surrounding surfaces (inside and outside)
- ▶ End faces
- ▶ Gear teeth
- ▶ Threads
- ▶ Smooth surfaces
- ▶ Bearing points

DIFFERENT DEGREE OF AUTOMATION

- ▶ Simple dosing heads for customer-side control
- ▶ Optionally with workpiece recognition for evaluation by the customer
- ▶ Self-sufficient devices with pneumatic or electric control e.g. manual devices, drawer solutions, ...

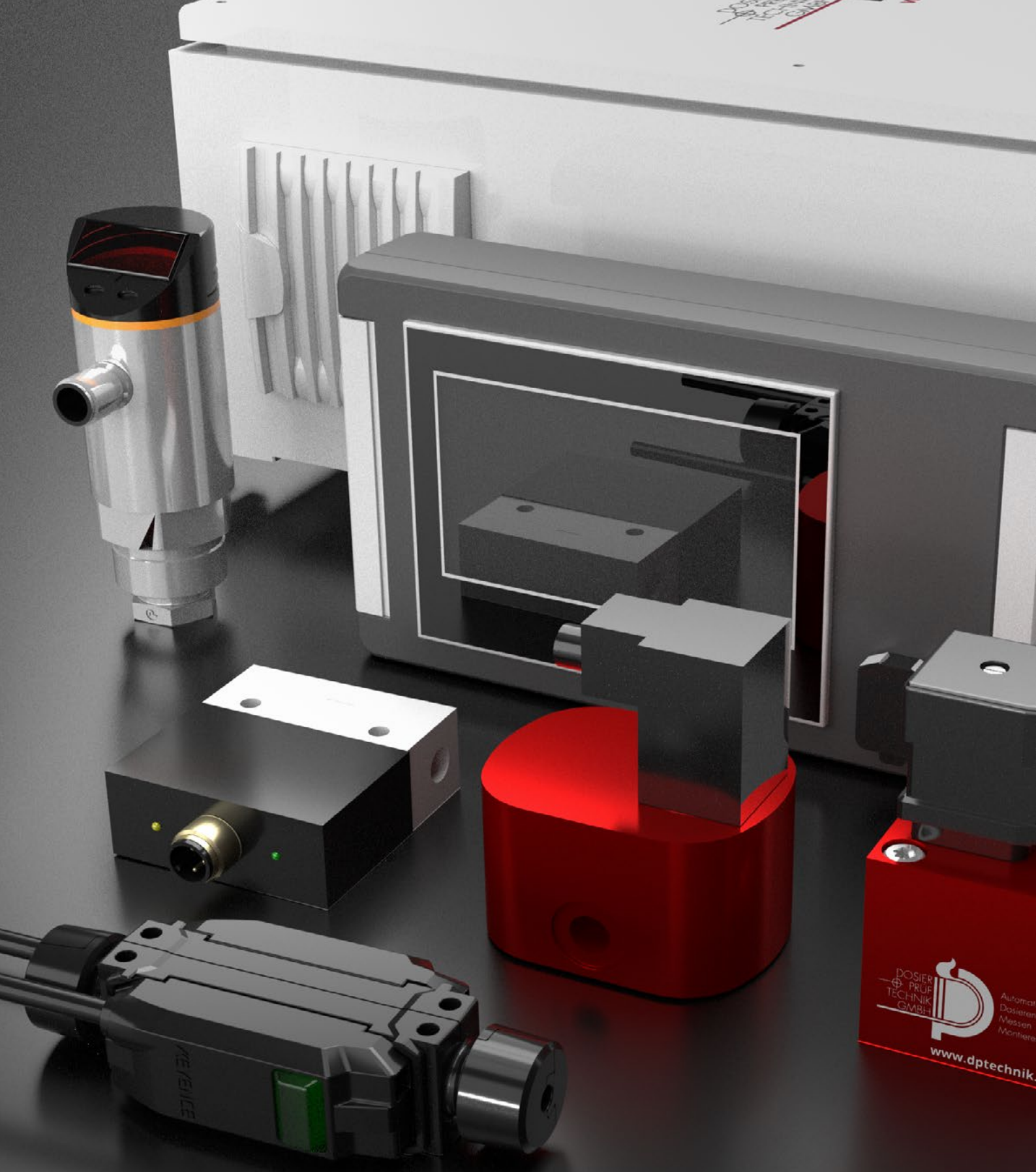

DOSIER
PRÜF
TECHNIK
GMBH
Automat.
Dosieren
Messen
Montieren
www.dp-technik.com



CONTROLLING MEASURING



OVERVIEW

Dosing controller	72
Flow meters	74
Volume sensors	78
Ultrasonic flow sensor	81

New challenges from our customers, increasingly precise evaluations and more and more data communication require modern, high-performance control systems and monitoring modules. This is because incorrect application of liquids during automatic dosing processes, primarily caused by flow failure, can lead to significant malfunctions.

Our high-performance sensors and Overview dosing controllers guarantee you full control and absolute process reliability for every dosing process.



DOSING CONTROLLER DS03

DP-D-004-000060



APPLICATION

The dosing controller is specially designed for the control and monitoring of dosing processes in industrial plants as well as stand-alone devices.

DESCRIPTION

- ▶ **Automatic mode:**
The application-specific sequences are started and stopped by a higher-level PLC, the touch panel, digital I/O signals or even pushbuttons. The result of the dosing is reported or displayed accordingly
- ▶ **Semi-automatic operation:**
Sub-processes of the system can be started/stopped and monitored manually. This is also possible via "remote control" from a higher-level PLC
- ▶ **Manual operation:**
All actuators can be controlled and monitored manually via the touch display. Likewise, states of the sensors integrated in the system are displayed or forwarded to higher-level systems.
- ▶ **User account management:**
Users and access authorizations (can be) created, changed, copied or deleted. This data can be stored externally on a medium (e.g. USB stick) and can also be restored from there.

ADVANTAGES

- ▶ Two-part system architecture: control cabinet with remote operating panel
- ▶ Modern user interface with graphical visualization and touch operation on a 7" display
- ▶ All available motor variants are applicable (e.g. stepper motor, servo motor, DC and three-phase motor)
- ▶ Control can also be used as Profinet master
- ▶ Controller is fail-safe capable and can control or monitor assigned protected areas
- ▶ Secure communication via Profisafe optionally possible
- ▶ The standard communication interface to the higher-level controller is Profinet.
- ▶ Clear, understandable diagnostic messages are shown directly on the display and sent as unique message numbers to the higher-level PLC. The message history can be stored externally.

TECHNICAL DATA	
Weight	50 kg
Length x width x height	controller box approx. 650 x 400 x 250 mm panel approx. 300 x 180 x 60 mm
Supply voltages	
Frequency	50 Hz
Max. power consumption	1.5 kW in full configuration with all metering components
Voltage	230 V AC or 24 V DC, depending on version
Environmental conditions	
Temperature	10–40 °C
Humidity	max. 70 %



DOSING SYSTEM DS03 ACCESSORIES

PROFIBUS INTERFACE DS03

DP-D-004-000062

Profibus interface for remote control of the system via a Profibus slave connection (e.g. start, stop, dosing control ready, dosing control fault, greasing IO and greasing NIO).

PROFISAFE INTERFACE DS03

DP-D-004-000072

APPLICATION

Interface for the exchange of safe signals (e.g. emergency stop...).

CONTROL

Interface for exchange of all other signals remains Profinet (e.g. start, stop, dosing control ready, dosing control fault, IO and NIO dosing).

DIGITAL I/O INTERFACE FOR DS03

DP-D-004-000061

APPLICATION

For job selection and transfer of status signals by means of digital inlets and outlets on the DS03 dosing system.

CONTROL

By the higher-level control (e.g. start, stop, dosing system ready, dosing system fault, lubrication IO and lubrication NIO). The dosing parameters are stored on the DS in the respective jobs.



EXTERNAL INDUSTRIAL POWER SUPPLY

- DP-D-004-000037
- DP-D-004-000038
- DP-D-004-000039
- DP-D-004-000040
- DP-D-004-000041

External industrial power supply incl. Rittal housing for power supply of the dosing system.

TECHNICAL DATA				
Type	DP-D-004-000037 (without FSV application)	DP-D-004-000038 (with FSV application)	DP-D-004-000039 (without FSV application)	DP-D-004-0040 (with FSV application)
Primary	230 V AC / 50 Hz (L1; N; PE)	230 V AC / 50 Hz (L1; N; PE)	230 V AC / 50 Hz (L1; N; PE)	230 V AC / 50 Hz (L1; N; PE)
Secondary	24 V DC / 10 A	24 V DC / 10 A	24 V DC / 20 A	24 V DC / 20 A



FLOW METER SMG06

D+P flow meters SMG06 immediately detect failures within a continuous application process. In case of discontinuous dosing of equal quantities, flow failures can also be detected accurately. D+P flow meters are ideally suited for monitoring almost all (viscous) liquids.

The modular and flexible design of the flow meters allows installation in new plants as well as integration into existing systems.

Flowmeters have been used successfully and reliably for many years in a wide variety of applications in assembly technology, automotive engineering, the pharmaceutical and chemical industries, the food industry, and many more.

The flow meters are a patent-protected proprietary development of D+P, Dosier- und Prüftechnik GmbH.

FUNCTIONALITY

The liquid deflects the sensor needle projecting into the adapter bore. The deflection is optically scanned, evaluated by the evaluation electronics and displayed. If the liquid flow contains an air bubble, this is detected and signaled.



EVALUATION ELECTRONICS FLC06

DP-S-006-000006

The processor-controlled evaluation electronics takes over the complete processing of the measuring signals supplied by the sensor. The measured value is shown on the bar display and continuously monitored for exceeding the programmed switching point.

The integrated sensor recognition enables continuous connection monitoring of the sensor. The operator can set the switching point, zero point, as well as pick-up and drop-out delay during operation via function keys.

The output signals must be recorded and evaluated with the aid of a higher-level control system.



SIGNAL TRANSMITTER DIGITAL

DP-S-006-000010

The signal transmitter is limited in its design to two electrical and one visual interface. The plug-in contacts can be used to connect the flow sensor and pass on the defined output signal. A green light diode is mounted in the center for visual control. If the flow sensor registers a deflection, the LED starts to light up green. The signal transmitter serves as an alternative to the FLC 06 evaluation electronics. The reduced design requires minimal space and thus increases flexibility for the end user. The functions have been limited to the essentials.

Thus, the digital signal generator shows the characteristic properties of a digital photoelectric sensor. The analog signal of the sensor needle is transferred to the module. Stabilized by means of an electronic circuit, it is sent digitally from there to a higher-level controller.



FLOW METER SMG06



CONNECTION ADAPTER SAE

The connection adapter is used to install the flow sensor in the medium-carrying pipeline.

A connection adapter with deflection amplifier makes it possible to monitor even the smallest quantities in the range of 0.005 g with very low viscosity media, such as sewing machine oil, contact oil, etc.

Stainless steel standard finish.

DIFFERENT VERSIONS

SAE 0,8/4	DP-S-004-000001
SAE 1,0/4	DP-S-004-000002
SAE 1,1/4	DP-S-004-000003
SAE 1,2/4	DP-S-004-000004
SAE 1,3/4	DP-S-004-000013
SAE 1,4/4	DP-S-004-000014
SAE 1,5/4	DP-S-004-000005
SAE 1,8/4	DP-S-004-000012
SAE 2,0/4	DP-S-004-000006
SAE 2,5/4	DP-S-004-000007
SAE 3,0/4	DP-S-004-000008
SAE 3,5/4	DP-S-004-000009
SAE 4,0/4	DP-S-004-000010
SAE 4,5/4	DP-S-004-000011



FLOW SENSOR SESL

A sensor needle projecting into the connection adapter detects the pressure of the medium flowing past. This pressure can be intensified by using a deflection amplifier. This makes it possible to detect even the smallest quantities and changes. Flow sensor made of stainless steel.

DIFFERENT VERSIONS

SESL 06-20	DP-S-002-000009
SESL 06-30	DP-S-002-000010
SESL 06-40	DP-S-002-000011
SESL 06-50	DP-S-002-000012
SESL 06-60	DP-S-002-000013
SESL 06-70	DP-S-002-000014
SESL 06-80	DP-S-002-000015
SESL 06-90	DP-S-002-000016



FLOW METER SMG06



CONNECTING CABLE VK06

For transmitting the measuring signals from the sensor to the evaluation electronics. Connecting cable with connector.

DIFFERENT VERSIONS		
VK 06-30	DP-S-005-000006	length = 3 m
VK 06-50	DP-S-005-000007	length = 5 m
VK 06-80	DP-S-005-000008	length = 8 m
VK 06-100	DP-S-005-000009	length = 10 m
VK 06-150	DP-S-005-000010	length = 15 m

FLOW TRANSMITTER SFG01 AND ADAPTER CABLE

DP-S-007-000001 // Flow transmitter SFG01-25
 DP-S-007-000003 // Flow transmitter SFG01-50
 DP-S-007-000002 // Adapter cable



The flow transmitter is used to monitor the metering process and is located between the metering and dispensing points. The flow of the metered medium is detected by a pistonstroke monitoring by means of a proximity switch.

TECHNICAL DATA		
Type	SFG01-25	SFG01-50
Stainless steel case	L 55 mm x Ø 25 mm	L 54 mm x Ø 25 mm
Installation height	60 mm	60 mm
Connection (medium)	2 x G 1/8" female thread	2 x G 1/8" female thread
Plastic inner pipe	flexible (WVN716 PA 12 H)	semi-rigid (WVN715 PA 12 H)
Counterpressure	0–25 bar	0–50 bar
Electrical connection	M8, 3-pole	M8, 3-pole
Cable length	approx. 200 mm	approx. 200 mm
Output	PNP circuit	PNP circuit



VOLUME SENSOR VCA0.04

DP-K-011-000002



The flow meter measures the moving dosing volume of liquids according to the gearwheel principle. A pair of gears fitted very precisely into the housing forms the measuring mechanism. The rotation of the measuring mechanism is detected tooth by tooth without contact by a signal pickup system and converted into digital pulses.

The integrated transducer with PNP outlet generates a pulse per tooth with a valence of 0.04 cm³.

The pulse frequency is proportional to the speed of the meter wheels, which are driven by the volume flow.

TECHNICAL DATA

Measuring range	0.004–4.00 l/min
Impulses	25.000 /l
P_{max}	200 bar
T_{max}	80 °C
Supply	10–30 V DC ± 10 %
Connection	G 1/4" lateral
Output	PNP
Adapter plug	DIN 43650A-M12



VOLUME SENSOR VC0.025

DP-K-011-000003



The measuring mechanism, which consists of two high-precision gear wheels, is driven by the liquid flow according to the displacement principle. The gears run almost contactless in the measuring chamber. Low-friction ball or plain bearings serve as bearing elements. Due to the measuring principle, no settling sections are necessary at the inlet and outlet. This means that machines/plants can be designed more compactly. All moving parts are lubricated by the measuring medium. The movement of the gearwheel is scanned contactlessly by two sensors in the cover as standard. When the measuring mechanism rotates by one tooth pitch, a signal is generated per sensor which corresponds to the so-called geometric tooth volume V_{gz} . The two-channel scanning enables a higher measured value resolution as well as a directional recognition of the flow.

TECHNICAL DATA

Specific data

Flow measuring range	0,008–2 l/min
Measuring unit start-up	bei 0,001 l/min
Linearised measurement accuracy	± 0.3 % of the measured value (at viscosity: min. 20 mm ² /s)
Repeatability	± 0,05 %
Resolution	40.000 pulses/l
Max. perm. pressure	200 bar
Operating fluid temperature	–15–120°C
Ambient temperature	–15–80°C
Max. foreign particle size	20 µm

Electrical data

Pulse volume	0.025 cm ³ /pulse
Line connection Pipe connection	G1/8"
Electronic output	2 square-wave signals, 90° offset
Electrical connection	Plastic angle plug – terminal strip Standard temperature version
Supply voltage	24 V DC ± 20 %

Materials

Material housing	Ductile cast iron EN-GJS 400
Material measuring unit	Steel 1.7139
Material O-rings	FKM
Bearing	Ball bearing



VOLUME SENSOR VSE01

DP-K-011-000001



The flow meter measures the moving dosing volume of liquids according to the gearwheel principle. A pair of gears fitted very precisely into the housing forms the measuring mechanism. The rotation of the measuring mechanism is detected tooth by tooth without contact by a signal pickup system and converted into digital pulses.

The integrated transducer with PNP outlet generates a pulse per tooth with a valence of 0.04 cm³.

TECHNICAL DATA	
Measuring range	0.004–4.00 l/min
Impulses	25.000/l
P _{max}	300 bar
T _{max}	100 °C
Supply	10–30 V DC ± 10 %
Output	PNP / NPN circuit
Adapter plug	–



ULTRASONIC FLOW SENSOR UDS

DP-K-011-000010 // UDS03 IO-Link
 DP-K-011-000011 // UDS04 IO-Link
 DP-K-011-000017 // UDS06 IO-Link
 DP-K-011-000019 // UDS08 IO-Link

DP-K-011-000012 // UDS03 Profinet
 DP-K-011-000013 // UDS04 Profinet
 DP-K-011-000018 // UDS06 Profinet
 DP-K-011-000022 // UDS08 Profinet



The UDS ultrasonic flow sensors are suitable for space-saving installations due to their small design. The clamp-on mechanism allows the flow to be checked from outside the pipe.

Because the sensors themselves do not come into contact with the medium, they do not require maintenance, there is no pressure loss with the medium and the pipe does not need to be modified. They have a repeatability of up to $\pm 0.1\%$ (depending on general conditions).

TECHNICAL DATA

Typ	UDS03	UDS04	UDS06	UDS08
Line outer diameter	3 mm	4 mm	6 mm	8 mm
Installable area	2.7–3.7 mm	3.5–4.5 mm	5.5–6.5 mm	7.5–8.5 mm
Nominal flow range	0–1000 ml/min			
Output	PNP or NPN circuit			
Zero cut flow rate	20 ml/min			
T _{max}	60 °C			
External inlet	selectable: zero flow rate / shot mode detection input / flow rate reset / zero offset.			

MOUNTING SET WITH SENSOR HEAD UDS03 // UDS04

(SPARE PART)

DP-K-011-000014 // mounting set with sensor head UDS03
 DP-K-011-000015 // mounting set with sensor head UDS04
 DP-K-011-000023 // mounting set with sensor head UDS06
 DP-K-011-000024 // mounting set with sensor head UDS08

CONSISTING OF

- ▶ Sensor Head
- ▶ Mounting set flow sensor and brackets

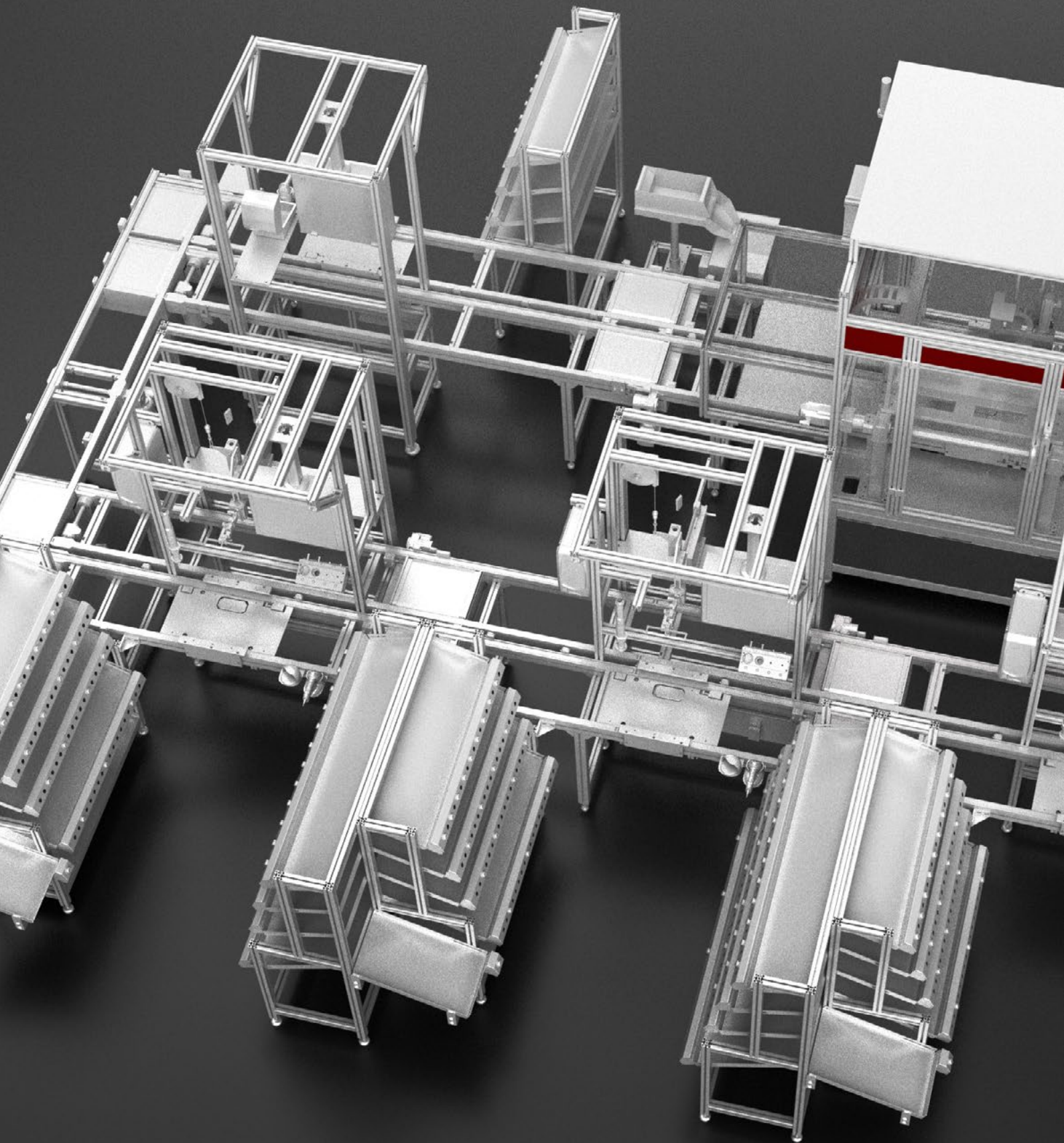

SPECIAL
MACHINERY



OVERVIEW

Robotics	84
Dispensing	85
Measuring / Testing	86
Automating / Assembling	87
Special solutions	88
Standard cells	89

Our customized solutions offer a wide range of functions and options to overcome a wide variety of challenges in different industries. Regardless of the specific task, we focus on understanding our customers' needs and offering innovative solutions.

We develop solutions that are adapted to the individual requirements and conditions in your production. Whether it's assembly, mounting, cutting or other tasks, we offer a variety of approaches to optimize your processes.

We use advanced technologies to guarantee the quality of your products and increase production speed at the same time. We make sure that our solutions can be seamlessly integrated into your existing processes.

We integrate advanced sensor technologies and vision systems to ensure that all processes run within the specified parameters.

We understand that production requirements can change over time. That's why we develop solutions that are adaptable and future-proof.



ROBOTICS

Robotic arms in special machine manufacturing offer numerous advantages. They increase productivity, improve product quality and reduce costs through greater efficiency. In addition, they are extremely flexible and can be used for a wide range of applications.

We offer our customers a manufacturer-independent, optimal robotics configuration. In this way, we can ensure that the robot arms are precisely matched to the individual requirements and applications of our customers.

ROBOT CELL WITH FLEXIBLE COMPONENT FEEDERS

- ▶ Fully automatic robotic cell incl. pad printing and assembly station
- ▶ 3D position detection of loosely poured components by means of reaching into the crate / 3D bin picking
- ▶ Highest possible degree of flexibility with a high number of variants
- ▶ Components are placed on the rotary table in tenths of a millimeter thanks to fully automatic, collision-free path planning
- ▶ flexible component feeding by means of feeder system and camera technology for the small parts
- ▶ easy integrability of new component types ensures high customer benefit even beyond the life cycle of individual products

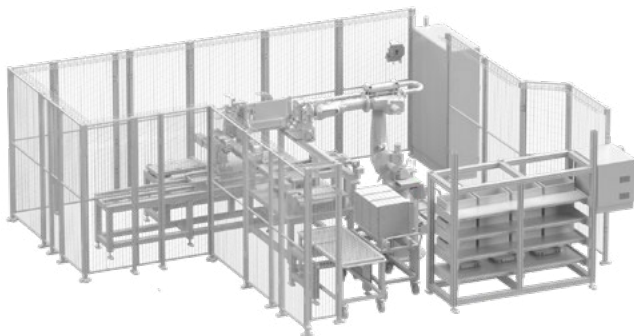
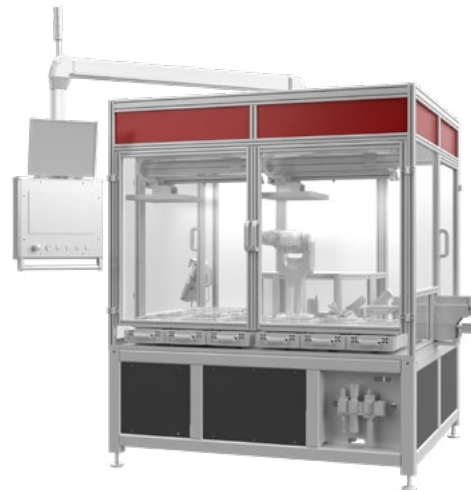

RELOADING CELL FOR CARBIDE RODS

- ▶ Automatic reloading cell for carbide rods
- ▶ High degree of autonomy
- ▶ Stacking magazines for component crates
- ▶ Automated insertion of separators into crates
- ▶ Component cassettes have RFID system
- ▶ Combination of robot handling and electric axis gantries
- ▶ Magnetic gripper system for component handling (in-house development)
- ▶ SAP connection

SOLDERING ROBOT SX

- ▶ Soldering system for SX molds
- ▶ Automatic dosing application of smallest quantities (punctual or linear)
- ▶ Feeding of components via drawer system and customer baskets
- ▶ Position and rotation determination of the components by means of camera and illumination system
- ▶ Solder foil is supplied and separated as bulk material by means of a vibratory feeder including integrated camera system
- ▶ Integrated inline soldering station with pyrometer monitoring

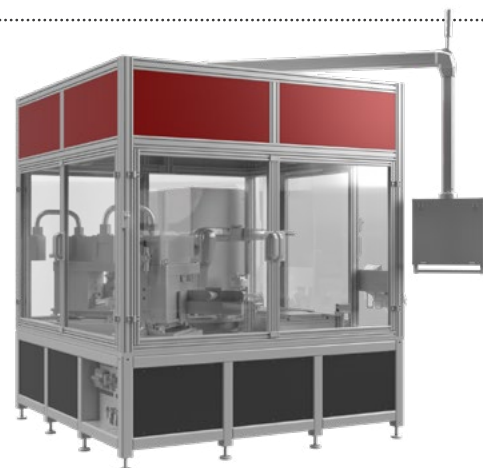



DISPENSING

Specifically for your applications, we offer a wide range of solutions for fully automated uninterrupted bead dosing or even semi-automated dispensing and filling systems that enable the precise dosing and application of viscous media onto surfaces or into containers.

CASTING CELL FOR DAMPER

- ▶ Electric 3-axis gantry for moving the metering unit (dispensing unit)
- ▶ Double 1C casting unit incl. material supply and flow sensor
- ▶ Dosing needle monitoring by means of laser measuring unit
- ▶ Dual drawer system for continuous silicone oil casting
- ▶ Simple recipe management as well as clearly structured and user-friendly visualization

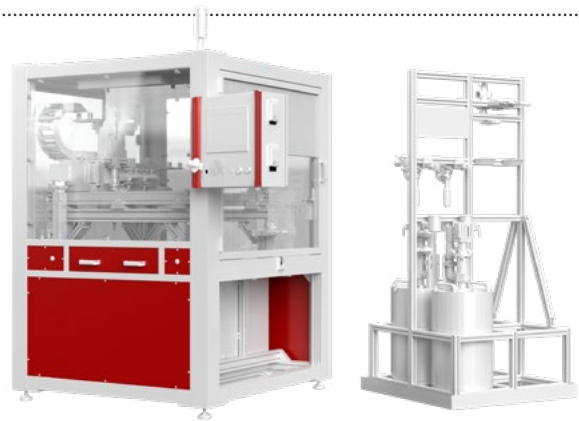

NC DOSING PORTAL

- ▶ Due to the electrical 3-axis gantry with integrated interpolation capability, any contours (linear, point, circular motion) can be plotted
- ▶ The creation of new contours can be done by means of externally created CNC programs or by importing DXF files
- ▶ An interaction between metering and axle speed is given to ensure a clean and uniform metering bead

LOT APPLICATION AND PLACEMENT SYSTEM

- ▶ Fully automatic soldering and insertion system for indexable inserts
- ▶ Cycle time: 11 seconds
- ▶ Feeding of indexable insert bodies by means of workpiece carrier
- ▶ Magnetic gripper system positions base body on rotary indexing table
- ▶ Automatic carbide seat monitoring by means of sensors
- ▶ Automatic dosing application of very small quantities (punctual or linear)
- ▶ Camera system determines rotational position of carbide cutting edge
- ▶ Precise loading of the carbide cutting edge to 0.03 mm
- ▶ Finished part deposit by means of centric gripper

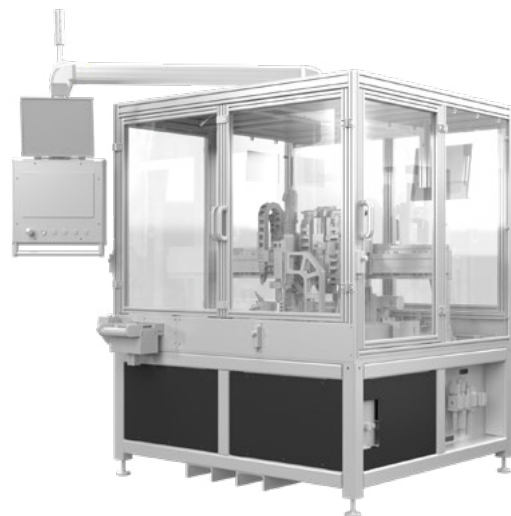



MEASURING / TESTING

Our services also include high-quality testing and measuring systems. Measuring and testing components and products often requires much more know-how and technical sophistication than their actual manufacture. For this reason, the requirements for the development and production of such systems are correspondingly high.

Here, too, you benefit from our decades of experience and strict quality controls, which enable us to guarantee the highest accuracy and repeatability in the performance of a wide variety of tests and measurements for every project.

TESTING EQUIPMENT FOR THREADED INNER AND OUTER PIPE

- ▶ Manual loading of the tubes by the worker
- ▶ Automatic thread testing for inner tube and outer tube
- ▶ Point probe incl. electrical feed movement
- ▶ Automatic handling for IO and NIO storage

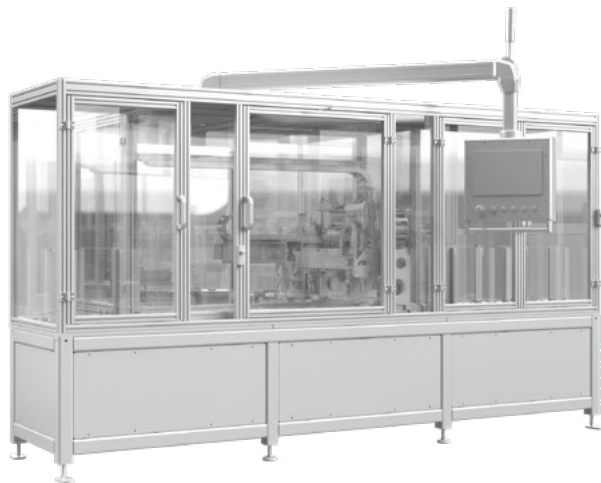
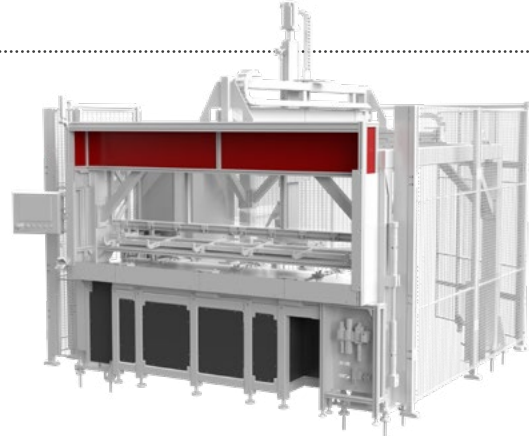

MEASURING STATION FOR INDEXABLE INSERTS

- ▶ Measuring station for indexable inserts
- ▶ Cycle time: 8 seconds
- ▶ Stacking magazine for customer blisters
- ▶ Recipe selection by the operator
- ▶ Electric rotary indexing table for component transport into respective test station
- ▶ Fast and highly precise measurement by means of profile projector using transmitted light method
- ▶ The profile shape of the component is recorded by laser triangulation
- ▶ Storage of tested inserts in sales packaging
- ▶ Revolver magazines for sales packaging can be emptied and loaded during ongoing test operation

TESTING EQUIPMENT FOR WOODEN BLOCKS

- ▶ 100% control for wooden blocks
- ▶ Different component shapes (cube, cuboid, triangle, crescent, etc.)
- ▶ Components are checked for burns, chipping, rough spots, etc. and selected in IO and NIO
- ▶ Cycle time: 180–200 pieces/minute
- ▶ A total of six high-resolution camera systems for each side of the building blocks
- ▶ Integrated lighting system adapted to the module color

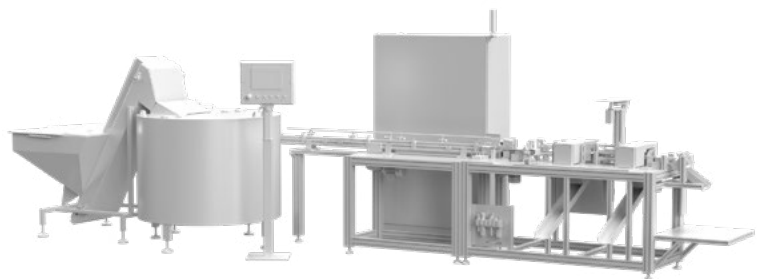



AUTOMATING / ASSEMBLING

The special machines manufactured by D+P include a wide range of automation solutions, including automatic screw-driving stations for the assembly of screws and other fasteners, rotary assembly machines for the assembly of complex assemblies, or semi-automatic assembly workstations for companies that want to optimize manual work processes through automation.

With our expertise in automation technology, we can integrate a wide range of processes to ensure high accuracy and a fast production rate.

DOUBLE SCREW STATION FOR ALUMINUM LIDS

- ▶ 3 different types of components
- ▶ Cycle time: approx. 11 seconds
- ▶ The assemblies are screwed together by two electrical 3 axis gantries incl. screw spindle
- ▶ A leading hold-down system provides torque support during the bolting process

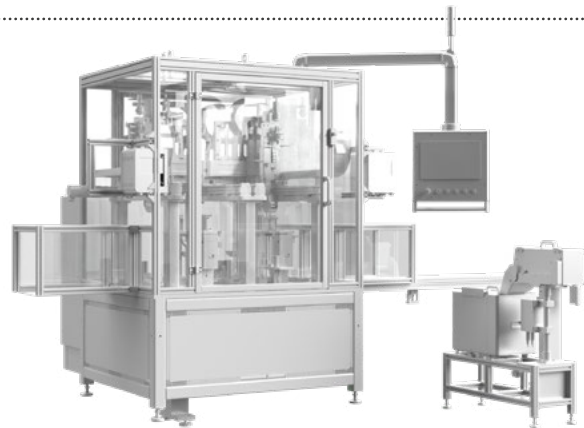

JOINING STATION FOR SERVO MOTORS

- ▶ Designed for different sizes and lengths
- ▶ Worker guidance through visualization
- ▶ Force, displacement and torque monitoring of the assembly processes
- ▶ Screw technology integrated into the assembly process
- ▶ Automatic entrainment and cutting to length of the strands during the joining process
- ▶ Partially automated unloading

MOUNTING STATION FOR AUTOMATIC ROTORS

- ▶ Designed for different sizes and lengths
- ▶ Force, displacement and torque monitoring of the assembly processes
- ▶ Pole check for each rotor pack
 - > Optical detection in the contact area for the operator
- ▶ Worker guidance through structured visualization
- ▶ Additional pole check in the machine to start the press-in only if the rotor pack is correct
- ▶ Rotating unit in lower component mount indexed by the necessary angular dimension for each rotor pack

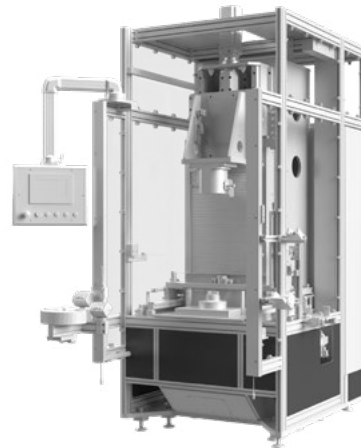



SPECIAL SOLUTIONS

Together with you, we develop individual special solutions for your areas of application. Interdepartmental coordination enables ideal consulting by our sales and project planning team. The primary goal is to meet the requirements exactly and to work out the best technical and economical solution in close cooperation with you.

WATER JET CUTTING MACHINE FOR CARBIDE RODS

- ▶ Paternoster unit for loading the carbide blanks
> continuous loading and unloading possible without process interruption
- ▶ Carbide blanks are cut to length fully automatically by water jet unit
- ▶ The bars, which are cut to length, are then separated by a wing straightening unit and gently placed on trays.

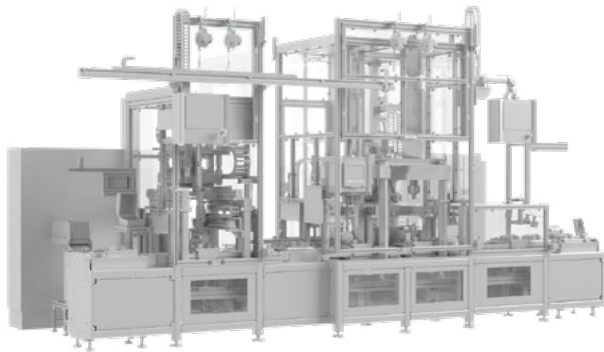
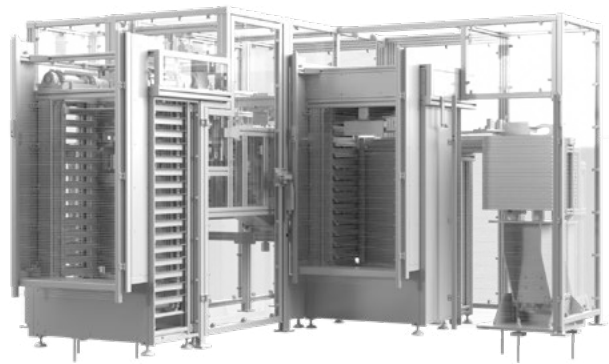

CUTTING AND SEPARATING MACHINE FOR CARBIDE RODS

- ▶ Manual width adjustment for trays or workpiece carriers possible (optionally this can also be done automatically by recipe selection on the touch panel)
- ▶ Loading and unloading side via paternoster units
- ▶ The two paternoster units can be loaded and unloaded during operation (no machine interruption during loading and unloading)
- ▶ Removal belt automatically adjusts to extruder speed based on sensor technology used

SUPPLY AND ASSEMBLY STATION FOR ALUMINIUM FLANGE

- ▶ 3 different types of components,
- ▶ Cycle time: approx. 11 s, autonomy time: approx. 120 min
- ▶ The door can be unlocked from the belt bunker by scanning the bar code > This prevents the worker from loading the wrong components
- ▶ By means of an upstream camera system, the position of the aluminum flange is determined and transmitted to the control system.
- ▶ The assembly process is carried out by means of electric 2-axis gantry and integrated 360 turning unit
- ▶ RFID read/write unit at the system infeed is used to determine which component is required
> uninterrupted production from batch size 1 onwards

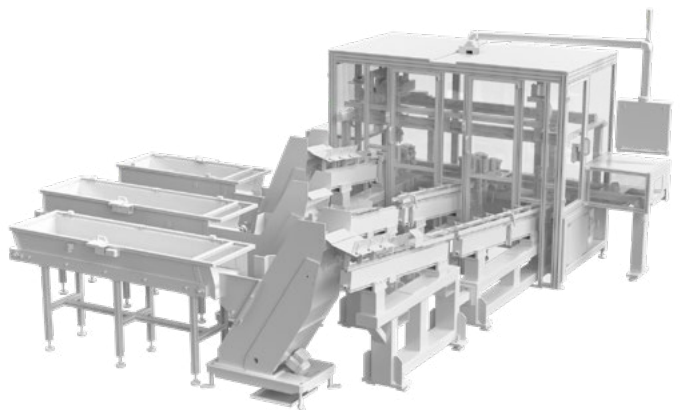



STANDARD CELLS

Discover our versatile solutions - from individual special machines to expandable tray palletizers and flexible assembly cells. With stable constructions, modular design and standardized components, we offer maximum adaptability for a wide range of applications. Interchangeable components enable customer-specific adaptations on site, while modular assembly allows efficient use according to requirements.

ASSEMBLY CELLS

Assembly cells from D+P offer the greatest possible flexibility. Thanks to the stable and standardized design, there is space in the cell for a wide variety of process units. The cell can also be expanded as required to cover a wide range of applications.

The modular design and standardized components ensure rapid availability and maximum integration with minimum space requirements.

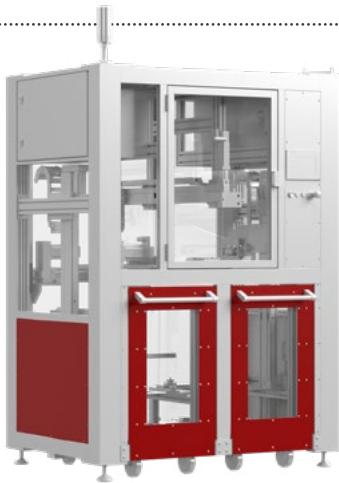

PALLETIZING CELLS

The tray palletizer from D+P is suitable for various loading and unloading tasks. The system can be extended by an intermediate position, which enables a partial inspection or NIO discharge position.

The basic structure consists of a sturdy aluminum profile tube frame. This is clad with Makrolon panes and powder-coated sheet metal.

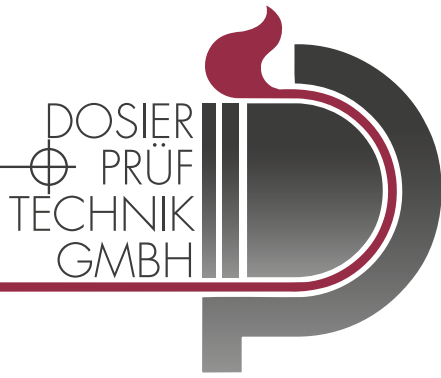

Automatisieren
Dosieren
Messen
Montieren

EXACTLY YOUR **SOLUTION!**



CONTACT

D+P, Dosier- u. Prüftechnik GmbH
Emil-Eigner-Straße 3
D-86720 Nördlingen
Fon: +49 9081 27593 0
E-Mail: info@dptechnik.de



01.2024

www.dptechnik.com